

Bonitron Success Story

Industry

Shipboard
Refrigeration

Application

Centrifugal
Compressor

OEM

Danfoss Turbocor

Third Party Testing

EPRI

End User

Cofely
Germany

Bonitron Product

M3460R-H150-R11-F

Specification

Single VFD 150kW
2 Second 50% Sags

AC / DC Bus
Connection

Ride Thru Voltage Regulator / Booster

150kW Open Chassis UPD Sized to Compressor Inverter Load

Single Unit Sag Protection for Centrifugal Compressor Inverter

In the refrigeration industry it is critical to maintain cooling for refrigerated products. Refrigeration systems down time means damaged or destroyed products. Refrigeration systems must maintain precise temperature controlled environments. Return on investment is seen in the amount of prevented product losses when chillers fail due to AC line sags.

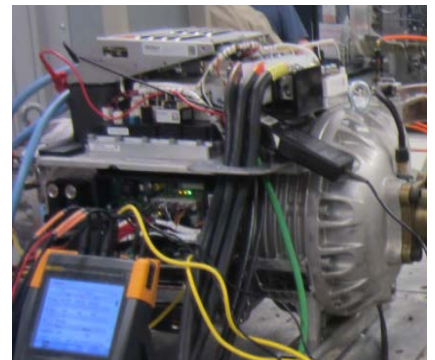
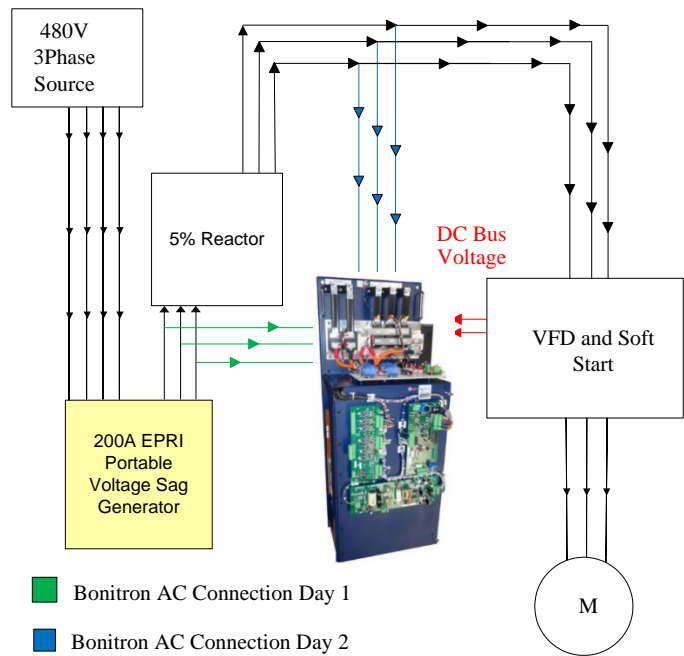

**150kW Compressor Provided by
Danfoss Turbocor**