



Model S3534BR
Battery Ride-Thru Systems

Customer Reference Manual

Bonitron, Inc.
Nashville, TN



An industry leader in providing solutions for AC drives.

ABOUT BONITRON

Bonitron designs and manufactures quality industrial electronics that improve the reliability of processes and variable frequency drives worldwide. With products in numerous industries, and an educated and experienced team of engineers, Bonitron has seen thousands of products engineered since 1962 and welcomes custom applications.

With engineering, production, and testing all in the same facility, Bonitron is able to ensure its products are of the utmost quality and ready to be applied to your application.

The Bonitron engineering team has the background and expertise necessary to design, develop, and manufacture the quality industrial electronic systems demanded in today's market. A strong academic background supported by continuing education is complemented by many years of hands-on field experience. A clear advantage Bonitron has over many competitors is combined on-site engineering labs and manufacturing facilities, which allows the engineering team to have immediate access to testing and manufacturing. This not only saves time during prototype development, but also is essential to providing only the highest quality products.

The sales and marketing teams work closely with engineering to provide up-to-date information and provide remarkable customer support to make sure you receive the best solution for your application. Thanks to this combination of quality products and superior customer support, Bonitron has products installed in critical applications worldwide.

AC DRIVE OPTIONS

In 1975, Bonitron began working with AC inverter drive specialists at synthetic fiber plants to develop speed control systems that could be interfaced with their plant process computers. Ever since, Bonitron has developed AC drive options that solve application issues associated with modern AC variable frequency drives and aid in reducing drive faults. Below is a sampling of Bonitron's current product offering.

WORLD CLASS PRODUCTS

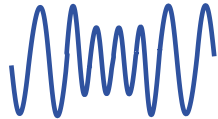

Undervoltage Solutions

Uninterruptible Power for Drives
(DC Bus Ride-Thru)
Voltage Regulators
Chargers and Dischargers
Energy Storage

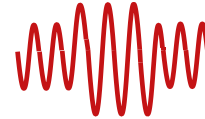

Overvoltage Solutions

Braking Transistors
Braking Resistors
Transistor/Resistor Combo
Line Regeneration
Dynamic Braking for Servo Drives

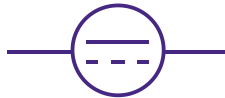

Common Bus Solutions

Single Phase Power Supplies
3-Phase Power Supplies
Common Bus Diodes



Portable Maintenance Solutions

Capacitor Formers
Capacitor Testers

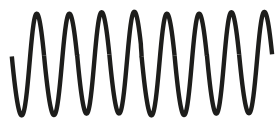

Power Quality Solutions

12 and 18 Pulse Kits



Green Solutions

Line Regeneration

1. INTRODUCTION	7
1.1. Who should use this Manual	7
1.2. Purpose and Scope	7
1.3. Manual Version and Change Record	7
Figure 1-1: Wall Mount and Floor Mount versions of S3534BR	7
2. PRODUCT DESCRIPTION	8
2.1. Related Products and Documents	8
2.1.1. Products	8
2.2. Part Number Breakdown	9
Figure 2-1: Example of Part Number Breakdown	9
Table 2-1: System Voltage Rating Codes	9
Table 2-2: Cabinet Information	10
2.3. General Specifications	10
Table 2-3: General Specifications Chart	10
2.4. General Precautions and Safety Warnings	11
3. INSTALLATION INSTRUCTIONS	13
3.1. Environment	13
3.2. Unpacking	13
3.3. Mounting	13
3.4. Wiring the S3534BR Ride-Thru Cabinet	13
3.4.1. Power Wiring	14
Table 3-1: Power Wiring Connections	15
Figure 3-1: Power Connections	15
Figure 3-2: User I/O Connections Detail	16
Figure 3-3: S3534BR Field Connection Terminal Layout	16
3.4.2. Control Interface and I/O Wiring	17
3.5. Typical Configurations	18
Figure 3-4: M3534B Typical Configuration with Battery Storage Bank and M3528 Charger	18
Figure 3-5: M3534B Typical Configuration with Battery Storage Bank and M5628 Charger	19
4. OPERATION	20
4.1. Functional Description	20
4.2. Startup Procedure	20
4.2.1. Pre-Power Checks	20
4.3. Shutdown Procedure	21
5. MAINTENANCE AND TROUBLESHOOTING	22
5.1. Field Test Procedure	22
5.2. Troubleshooting	23
Table 5-1: Troubleshooting Guide	23
5.3. Technical Help – Before you call	24
6. ENGINEERING DATA	26
6.1. Ratings Charts	26
Table 6-1: Model S3534BR Ride-Thru Module Voltage Levels	26
Table 6-2: Typical Storage Bank Configurations	26
6.2. Fuse/Circuit Breaker Sizing and Rating	26
Table 6-3: Input Power Wiring Sizes and Fusing	26
6.3. Dimensions and Mechanical Drawings	27
Figure 6-1: S3534BR D80 Cabinet Dimensional Outline	27
Figure 6-2: S3534BR D82 Cabinet Dimensional Outline	28

Table of Contents

Figure 6-3: S3534BR E71 Cabinet Dimensional Outline	29
Figure 6-4: S3534BR E70 Cabinet Dimensional Outline	30
<u>NOTES</u>	31

This page intentionally left blank

1. INTRODUCTION

1.1. WHO SHOULD USE THIS MANUAL

This manual is intended for use by anyone who is responsible for integrating, installing, maintaining, troubleshooting, or using this equipment with any AC drive system. Please keep this manual for future reference.

1.2. PURPOSE AND SCOPE

This manual is a user's guide for S3534BR 100% outage DC bus sag ride-thru systems. It will provide the user with the necessary information to successfully install, integrate and use the S3534BR cabinet in a variable frequency AC drive system. In the event of any conflict between this document and any publication and/or documentation related to the AC drive system, the latter shall have precedence.

1.3. MANUAL VERSION AND CHANGE RECORD

The initial release of this manual is Rev 00a.

Additional information in the Start-up Procedure and in Section 7 was given in Rev 01b. Multiple updates were made throughout the manual in Rev 02a.

Updated figure 3-4 and added figure 3-5 in Rev 02b.

Figure 1-1: Wall Mount and Floor Mount versions of S3534BR



2. PRODUCT DESCRIPTION

Bonitron S3534BR battery ride-thru systems provide protection from long term line voltage outages for variable frequency drives (VFDs) that use a fixed rectifier and DC bus. Providing power for outage times up to 4 minutes allows sufficient time for generator start up and transfer to auxiliary power.

Industries with continuous processes can suffer huge losses from equipment downtime, loss of production, or damaged product when VFDs trip on under-voltage conditions.

Traditional UPS solutions are connected in series, which decreases the overall drive system reliability. All Bonitron ride thru products connect in parallel with the drive, thus increasing system availability and reliability.

Bonitron S3534BR battery ride-thru systems provide ride through capability to handle outages by storing energy in battery banks and releasing it back into the drive's DC bus when needed. The internal M3534B boost module regulates the dropping battery voltage up to the drives desired DC bus level. This allows the drive to "ride through" these events while maintaining motor speed and torque, without experiencing drive shutdown.

A complete S3534BR battery backup system includes charger, isolation transformer, and booster. Batteries are sold separately.

2.1. RELATED PRODUCTS AND DOCUMENTS

2.1.1. PRODUCTS

S3534CR SERIES RIDE-THRU SYSTEMS

Complete systems that use electrolytic capacitor storage for short term power outages.

S3534UR SERIES RIDE-THRU SYSTEMS

Complete systems that use ultracapacitor storage for short term power outages.

S3534SR SERIES RIDE-THRU SYSTEMS

Complete systems for 50% line sag for 2 seconds.

M3534 SERIES RIDE-THRU MODULES

Voltage regulators used for sag or outage protection of higher power systems.

M3528 BATTERY AND ULTRACAPACITOR CHARGERS

Chargers for high voltage storage strings.

2.2. PART NUMBER BREAKDOWN

Figure 2-1: Example of Part Number Breakdown

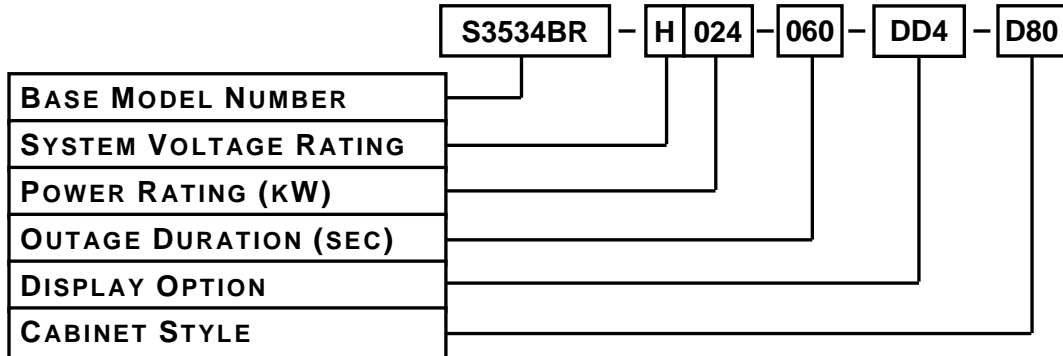

BASE MODEL NUMBER

The base model number for the battery regulator 100% outage, DC bus drive ride-thru is **S3534BR**.

SYSTEM VOLTAGE RATING

The system voltage rating indicates the nominal AC/DC voltage levels of the AC drive system is intended to support. A code letter indicates the system voltage.

Table 2-1: System Voltage Rating Codes

RATING CODE	VOLTAGES (NOMINAL AC LINE / DC BUS)
L	230VAC Line / 320VDC
E	380 - 415VAC Line / 540 - 585VDC
H	460VAC Line / 640VDC

POWER RATING (KW)

The power rating indicates the maximum power in kilowatts that can safely be handled by the S3534BR system.

This rating is directly represented by a 3-digit value based on the nominal DC system voltage rating and the maximum output current rating of the S3534BR. For instance, the code **24** indicates a 24kW S3534BR.

OUTAGE DURATION

The outage duration indicates the amount of time (in seconds) the S3534BR system is able to hold the DC bus at the threshold level while loaded to the rated current. This duration is directly represented by a 3-digit value. For example, **060** in this position represents 60 seconds of outage duration.

DISPLAY OPTION

The display option indicates which display is mounted on the front of the enclosure. The displays show the M3534 operating status and also permit a system test to be performed. The DD5 digital display has many more features than the DP10 analog display, including Sag and fault logging. Please refer to the ASM 3660DD5 manual for a full description of features.

CABINET STYLE

The cabinet is determined by the power rating.

Table 2-2: Cabinet Information

CHX CODE	TYPE	DIMENSIONS (H" x W" x D")
D80	Type-12	71" x 40" x 20"
D82	Type-12	79" x 40" x 20"
E70	Type-12	48" x 36" x 12"
E71	Type- 12	60" x 36" x 12"

2.3. GENERAL SPECIFICATIONS

Table 2-3: General Specifications Chart

PARAMETER	SPECIFICATION
System AC Voltage	208 - 480 VAC
Battery Bank Voltage Range	320 – 540 VDC
Output DC Voltage	285 – 585 VDC
DC Bus Current Rating (Max)	20 – 40 ADC
Power Rating (Range)	12 – 24kW
Outage Duration	2 – 60 seconds
Operating temperature	0 - 40° C
Storage Temperature	-20 - 65° C
Inactive Power Usage	Less than 25 W
Humidity	Below 90% non-condensing
Atmosphere	Free of corrosive gas and conductive dust

2.4. GENERAL PRECAUTIONS AND SAFETY WARNINGS



DANGER!

- **HIGH VOLTAGES MAY BE PRESENT!**
- **NEVER ATTEMPT TO OPERATE THIS PRODUCT WITH THE ENCLOSURE COVER REMOVED!**
- **NEVER ATTEMPT TO SERVICE THIS PRODUCT WITHOUT FIRST DISCONNECTING POWER TO AND FROM THE UNIT.**
- **ALWAYS ALLOW ADEQUATE TIME FOR RESIDUAL VOLTAGES TO DRAIN BEFORE REMOVING THE ENCLOSURE COVER.**
- **FAILURE TO HEED THESE WARNINGS MAY RESULT IN SERIOUS BODILY INJURY OR DEATH!**



CAUTION!

- **CERTAIN COMPONENTS WITHIN THIS PRODUCT MAY GENERATE HIGH AMBIENT TEMPERATURES DURING OPERATION.**
- **ALWAYS ALLOW AMPLE TIME FOR THE UNIT TO COOL BEFORE ATTEMPTING SERVICE ON THIS PRODUCT.**
- **BEFORE ATTEMPTING INSTALLATION OR REMOVAL OF THIS PRODUCT, BE SURE TO REVIEW ALL DRIVE AND/OR RESISTIVE LOAD DOCUMENTATION FOR PERTINENT SAFETY PRECAUTIONS.**
- **INSTALLATION AND/OR REMOVAL OF THIS PRODUCT SHOULD ONLY BE ACCOMPLISHED BY A QUALIFIED ELECTRICIAN IN ACCORDANCE WITH NATIONAL ELECTRICAL CODE OR EQUIVALENT REGULATIONS.**
- **THIS PRODUCT DOES NOT PROVIDE MOTOR OVERLOAD PROTECTION.**

ANY QUESTIONS AS TO APPLICATION, INSTALLATION, OR SERVICE SAFETY SHOULD BE DIRECTED TO THE EQUIPMENT SUPPLIER.

This page intentionally left blank

3. INSTALLATION INSTRUCTIONS



Installation and/or removal of this product should only be performed by a qualified electrician in accordance with National Electrical Code or local codes and regulations.

Proper installation of the S3534BR battery ride-thru should be accomplished following the steps outlined below. Be sure to refer to the AC drive instruction manual as these steps are performed. Please direct all installation inquiries that may arise during the installation and startup of this product to the equipment supplier or system integrator.

3.1. ENVIRONMENT

The maximum operating temperature of the ride-thru system should not exceed 40°C.

3.2. UNPACKING

Upon receipt of this product, please verify that the product received matches the product that was ordered and that there is no obvious physical damage to the unit. If the wrong product was received or the product is damaged in any way, please contact the supplier from which the product was purchased.

3.3. MOUNTING

1. Move the cabinet to the desired installation site.
2. Remove the hardware securing the cabinet to its pallet.
3. Using a crane or hoist connected to the cabinet's lifting eyes, remove the cabinet from the pallet, and set it in the desired location.
 - Secure the S3534BR cabinet in place. Cabinets may be anchored to the floor as necessary.
 - The systems may come with separate cabinets, and the battery cabinet may be quite heavy compared to the booster cabinet.

3.4. WIRING THE S3534BR RIDE-THRU CABINET

Review this entire section before attempting to wire the S3534BR



Interconnect wiring of this product should only be performed by a qualified electrician in accordance with National Electrical Code or local codes and regulations.



**THE S3534 CAN HAVE MULTIPLE POWER SOURCES, INCLUDING THE MAIN AC INPUT, ENERGY STORAGE SYSTEMS AND THE DC CONNECTION TO THE VFD.
ENSURE THAT ALL SOURCES ARE DISCONNECTED AND LOCKED OUT BEFORE ATTEMPTING SERVICE OR INSTALLATION.
FAILURE TO HEED THESE WARNINGS MAY RESULT IN SERIOUS INJURY OR DEATH!**

3.4.1. POWER WIRING

This section provides information pertaining to the field wiring connections of the S3534BR ride-thru cabinet system. Actual connection points and terminal numbers of the AC drive system will be found in the documentation provided with that drive system.

Be sure to review all pertinent AC drive system documentation before proceeding.

3.4.1.1. POWER CONNECTIONS

AC LINE (L1, L2, L3) CONNECTIONS

During operation, the load on the AC line is used for charging and maintaining the battery storage modules.

DC BUS (+ -) CONNECTIONS

The S3534BR must have a DC bus connection directly to the DC bus filter capacitors within the drives. Connections cannot be made through the braking terminals, with precharge resistors, or with DC link chokes between the output of the S3534BR and the DC bus capacitors in the drive. Consult the drive manufacturer's documentation or contact Bonitron for further assistance.

Make sure the polarity is correct for these connections, as failure to do so can cause severe damage to the system.

GROUNDING REQUIREMENTS

Cabinet should be earth grounded to the stud in upper right corner of the backplate.

BATTERY BANK REQUIREMENTS

Battery bank wiring should be sized to carry the full load current of the DC input at full load.

The battery bank should be disabled by removing the center link of the battery string before wiring. This will not allow the battery bank to discharge if there is a wiring fault or short while these connections are being made.

Table 3-1: Power Wiring Connections

(kW)	TERMINAL	FUNCTION	ELECTRICAL RATINGS	WIRE SIZE MIN.	WIRE SIZE MAX.	TORQUE
10 - 12kW	DSC1-1	DC Output +	650 VDC, 20 A	14 AWG	8 AWG	7 - 14 lb-in
	DSC1-2	DC Output -	650 VDC, 20 A			7 - 14 lb-in
	DSC1-3,4,5	AC Input	460 VAC, 30 A			7 - 14 lb-in
	Battery Bank (+), (-)	Storage BUS (+), (-)	650 VDC, 30 A	12 AWG	8 AWG	40 - 50 lb-in
	GND	System Ground	Limited by Ring Lug 3/8"			40 - 50 lb-in
20 - 24kW	DSC1-1	DC Output +	650 VDC, 40 A	14 AWG	8 AWG	7 - 14 lb-in
	DSC1-2	DC Output -	650 VDC, 40 A			7 - 14 lb-in
	DSC1-3,4,5	AC Input	460 VAC, 60 A			7 - 14 lb-in
	Battery Bank (+), (-)	Storage BUS (+), (-)	650 VDC, 60 A	12 AWG	4 AWG	40 - 50 lb-in
	GND	System Ground	Limited by Ring Lug 3/8"			40 - 50 lb-in

Figure 3-1: Power Connections

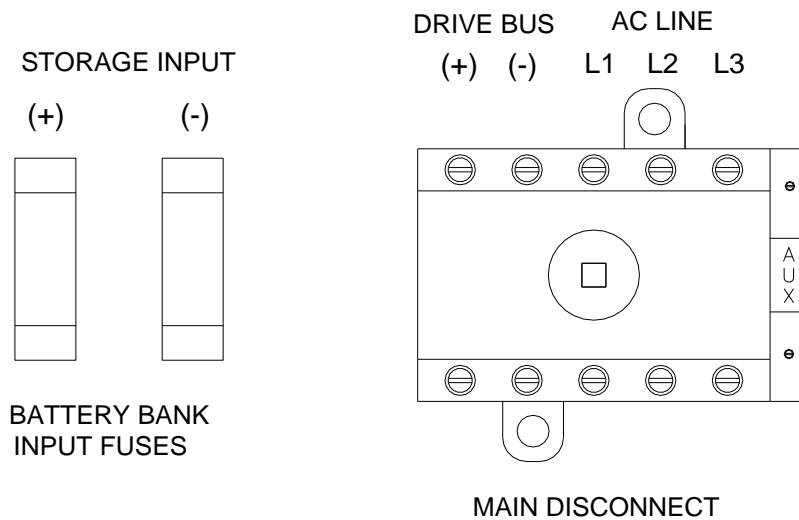

Figure 3-2: User I/O Connections Detail

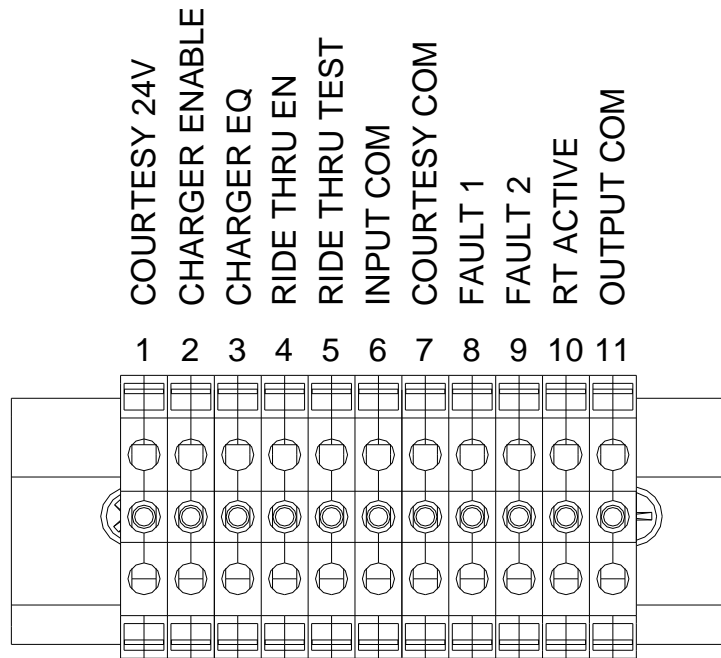
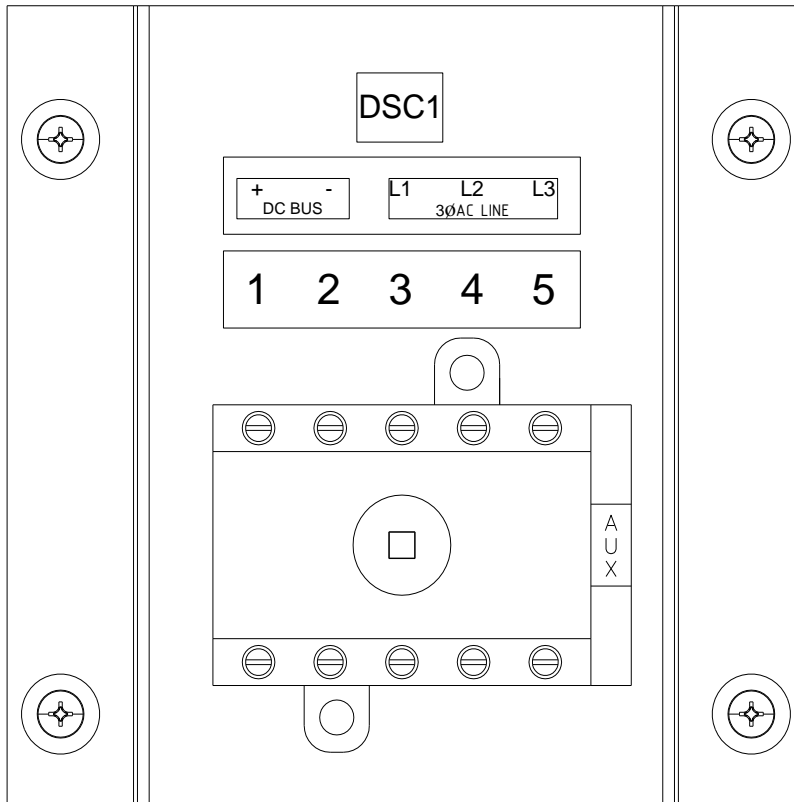

Figure 3-3: S3534BR Field Connection Terminal Layout



3.4.2. CONTROL INTERFACE AND I/O WIRING

The control interface and I/O Wiring originate from the M3534 ride-thru Module. Please see the M3534 manual for further information on these outputs.

Table 3-2: User I/O Terminal Connections for Cabinets

TERMINAL	FUNCTION
TB – 1	Courtesy + 24V
TB – 2	Charger ENABLE
TB – 3	Charger Equalize (EQ)
TB – 4	Ride-Thru ENABLE
TB – 5	Ride-Thru TEST
TB – 6	Input COM
TB – 7	Courtesy COM
TB – 8	Fault 1
TB – 9	Fault 2
TB – 10	Ride-Thru Active (RTA)
TB – 11	Output COM

3.5. TYPICAL CONFIGURATIONS

Figure 3-4: M3534B Typical Configuration with Battery Storage Bank and M3528 Charger

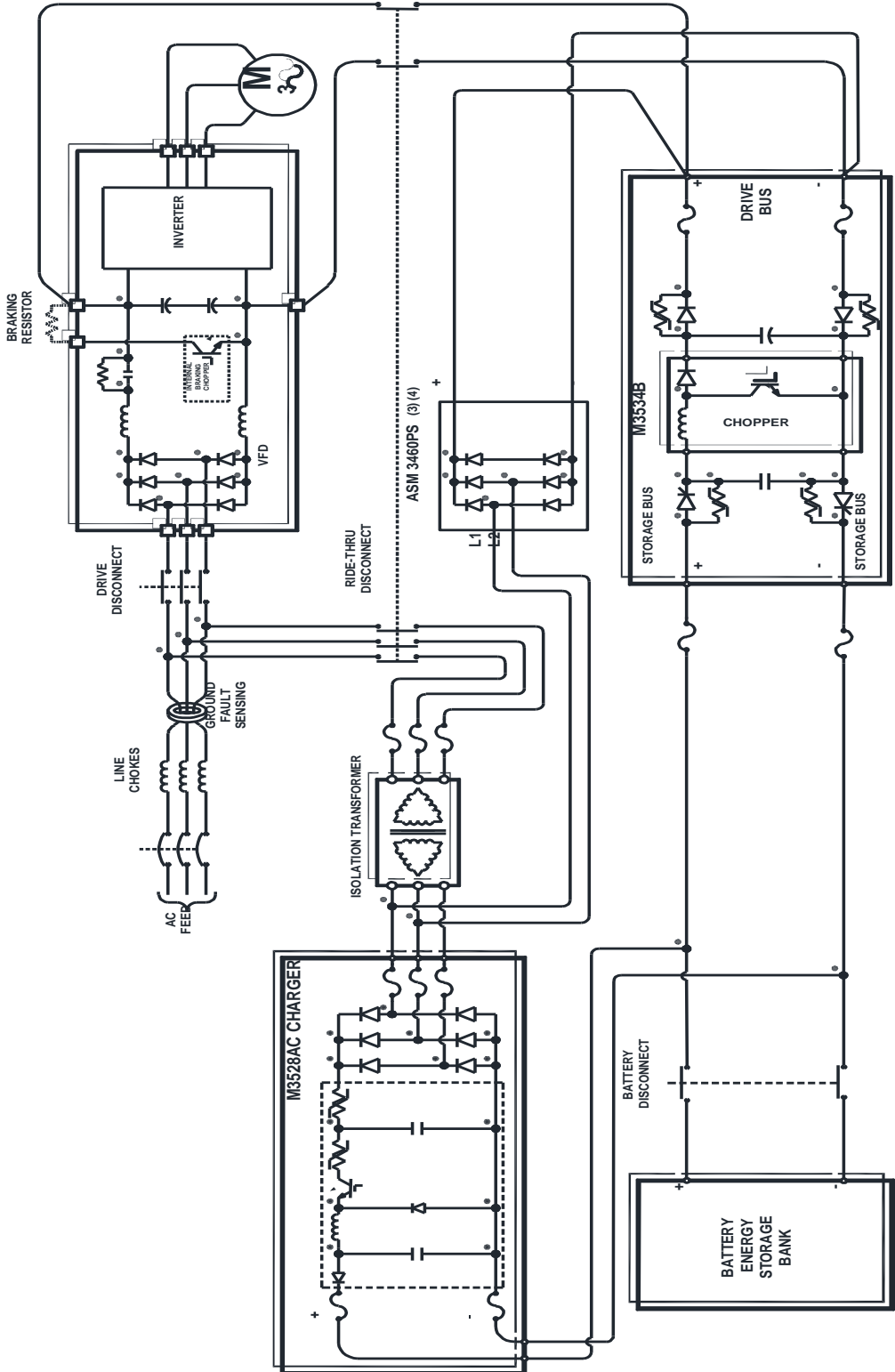

- NOTES-
1. INVERTER AND RIDE-THRU SHOULD BE POWERED FROM THE SAME FEED TRANSFORMER.
 2. IF LINE CHOKES ARE USED, RIDE-THRU MUST BE CONNECTED DOWNSTREAM.
 3. ASM 3460PS WILL BE USED WHEN EQUIPPED WITH DIODE MODULE M3460D.
 4. ASM 3460PS WILL PROVIDE THE DC VOLTAGE NEEDED FOR SYSTEM PRECHARGE.

Figure 3-5: M3534B Typical Configuration with Battery Storage Bank and M5628 Charger

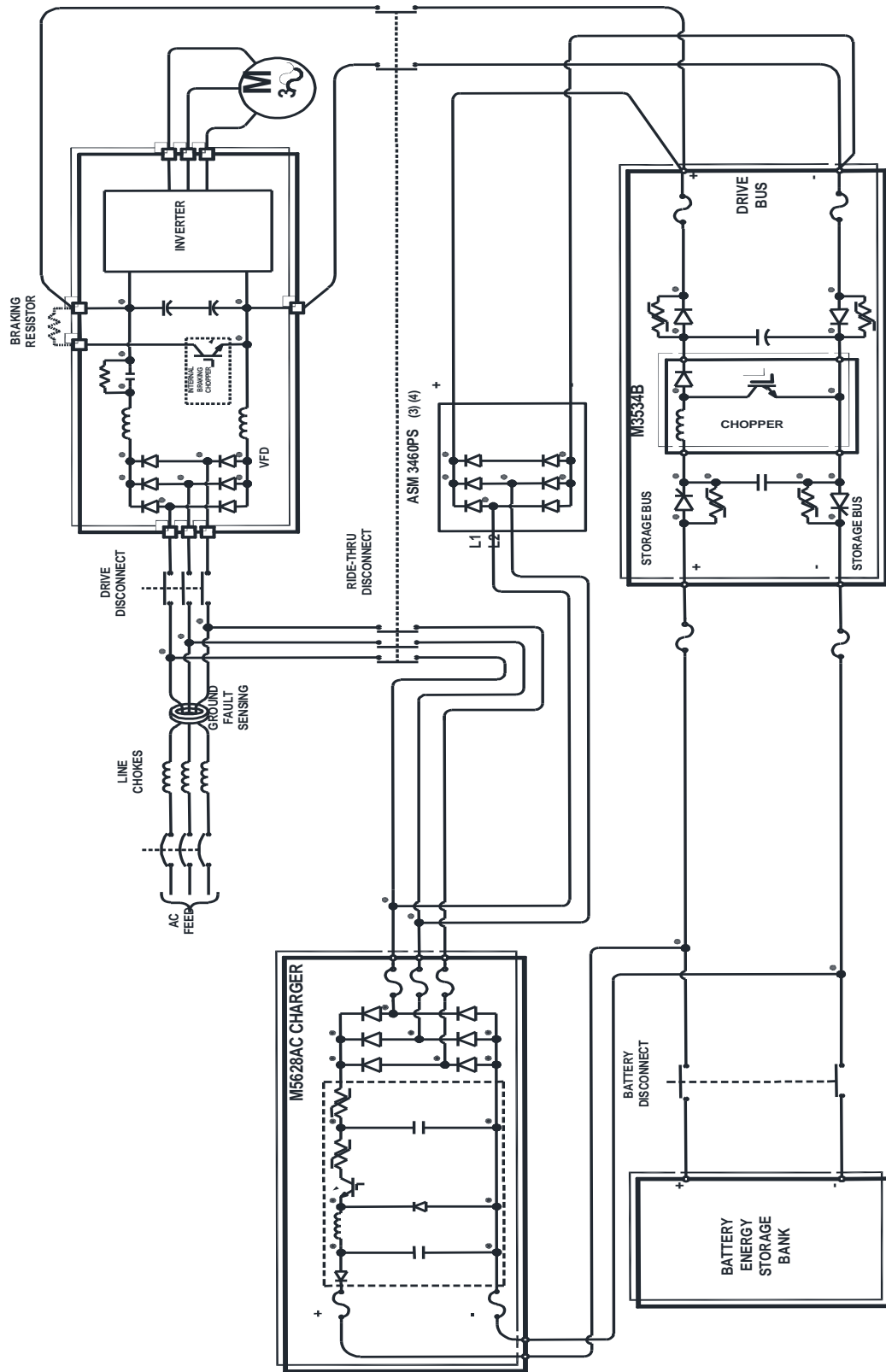

-NOTES-

1. INVERTER AND RIDE-THRU SHOULD BE POWERED FROM THE SAME FEED TRANSFORMER.
2. IF LINE CHOKES ARE USED, RIDE-THRU MUST BE CONNECTED DOWNSTREAM.
3. ASM 3460PS WILL BE USED WHEN EQUIPPED WITH DIODE MODULE M3460D.
4. ASM 3460PS WILL PROVIDE THE DC VOLTAGE NEEDED FOR SYSTEM PRECHARGE.

4. OPERATION

4.1. FUNCTIONAL DESCRIPTION

The S3534BR ride-thru system monitors the DC bus of the attached variable frequency drive (VFD) and provides power in a voltage controlled, current limited supply directly to the filter capacitor section of the drive above the inverter stage. During a power quality event, such as a sag or power outage, the internal DC bus of the VFD drops. When this level meets the DC bus threshold voltage of the S3534BR, power is delivered through blocking diodes to hold up the voltage in the VFD bus.

Energy is stored in a battery bank and the boost module regulates and boosts the output voltage to the drive at a constant voltage.

In standby mode, or when the incoming AC power is normal, the system recharges the battery bank and holds the energy storage at a constant level. Once the battery bank is charged, the standby energy consumption is minimal.

4.2. STARTUP PROCEDURE

4.2.1. PRE-POWER CHECKS

- Ensure the ride-thru has been properly installed as per the instructions in Section 3 of this manual.
- Check the polarity of the DC bus connection to the VFD at the disconnect. It is critical that this is correct.
- Initialize the battery cabinet. High voltage battery cabinets are shipped with links missing. This prevents the battery bank from discharging during shipment if there is an accident or short.
- Verify that the battery disconnect or breaker switch is OFF
- Re-connect battery bank link as instructed by battery bank documentation package provided by the battery bank manufacturer.
- Measure the battery string voltage. This should be above the nominal battery string voltage.
- Turn on the battery system with the breaker inside the battery cabinet.
- The ride-thru DC bus threshold must be coordinated with the under voltage trip setting of the VFD. If the threshold is too close to the nominal bus, the ride-thru may supply power to the drive continuously, and overheat. If the threshold is too close to the under voltage trip level of the VFD, under voltage faults may still occur. Most VFDs have an undervoltage trip point of 15% below the nominal voltage level.
- Apply ENABLE command.
- Power up the attached drive system. This should be done according to the procedure for the VFD. Ensure that the associated VFD is working properly prior to connecting to the ride-thru system.
- Connect the inverter load by closing the main disconnect switch.
- When the drive is fully loaded and the DC bus level drops, some residual current up to 0.5 ADC may flow from the ride-thru to the drive's bus.
- Verify that the energy storage bank is fully charged.
- Remove the AC power from the fully loaded drive system simulating an outage event.

- The DC bus voltage should drop and hold at the threshold voltage level.
- Ride-Thru Active indicator turns ON.
- DC input will drop as the batteries discharge.
- Motor speed should remain constant.

4.3. SHUTDOWN PROCEDURE

1. Remove the enable signal to the M3534 booster module.
2. Turn off the AC input using the main disconnects. This will disconnect incoming AC power and the output DC power to the VFD.
3. Turn off the battery disconnect switch within the battery cabinet. This will remove the backup energy storage from the main booster cabinet.
4. Allow 5 minutes for the residual voltage in the booster cabinet to drain before opening the cabinet. This will be indicated by the voltage indicator on the front of the panel.

5. MAINTENANCE AND TROUBLESHOOTING

Repairs or modifications to this equipment are to be performed by Bonitron approved personnel only. Any repair or modification to this equipment by personnel not approved by Bonitron will void any warranty remaining on this unit.

5.1. FIELD TEST PROCEDURE

The Bonitron S3534BR ride-thru system is designed to be low maintenance. However, the connected energy storage battery bank will degrade over time, and should be periodically checked. Bonitron recommends a yearly test of the system in order to ensure the electronics package is operating properly, and the storage bank has proper capacity. The following steps can be taken to ensure reliability that the system is still able to ride-thru an outage event.

Each Bonitron ride-thru should be tested under load during initial start up to verify the functionality of the test circuit and that the test does not negatively affect the process. However, Bonitron recommends that if the process is critical, the test cycle be initiated only during a scheduled shutdown.

- Ensure the S3534BR has been properly installed and is disabled.
- Ensure the AC line input, drive bus, and battery bank are all installed properly to the cabinet disconnect.
- Turn on the cabinet disconnect and observe the display status. The status should display Ride-Thru Ready. If there are faults on the system, turn off power and check the ASM 3660DD4 and the M3534 manuals for further troubleshooting details.
- Enable the S3534BR with either the Enable input or the digital display.
- Load the VFD as much as is practical for testing.
- Initiate the test mode with the display panel to confirm that the booster is working properly.

The DC bus should rise for about 100VDC above the normal DC bus level.

- Verify energy storage bank charge by removing AC power to the drive simulating an outage event.
 - The DC bus voltage should drop to the threshold voltage level.
 - Ride-Thru Active indicator turns ON.
 - DC bus voltage should hold at the threshold voltage level.
 - The drive should continue to run normally.
 - Motor speed should remain constant.
 - The system should only be allowed to run for a maximum of 4 minutes.
 - Re-apply the AC power to the inverter input.

5.2. TROUBLESHOOTING

Table 5-1: Troubleshooting Guide

SYMPTOM	ACTION
No front panel LEDs	<ul style="list-style-type: none"> • Check incoming power • Check power supply from booster • Check 24V RUN command
RTA always ON	<ul style="list-style-type: none"> • Check DC Bus levels on DRT panel and drive panel • Check for overheated precharge circuit <ul style="list-style-type: none"> • Too much activity can cause stage fuse failures, overheating and draining of the battery • Check threshold level, if changed over time adjust level or replace booster module
RTA never ON	<ul style="list-style-type: none"> • Check RUN command • Initiate test cycle or remove power <ul style="list-style-type: none"> • Watch and listen for signs of activity <ul style="list-style-type: none"> • Check RTA contact and LED • Ticking sound • Check power quality data to confirm sag events should have caused activity to occur • If never any activity, replace booster module
Overtemp	<ul style="list-style-type: none"> • Check for constant current on the negative or positive DC bus links • Check temp sensors on IGBT heatsink and on chokes • Check activity record – too much activity may cause Overtemp • Check precharge network for overheating
TEST won't work	<ul style="list-style-type: none"> • Check DC bus level – too high causes no test • Check TEST jumper on back of display PCB
Voltage fluctuates during TEST mode	<ul style="list-style-type: none"> • Check threshold and test boost level settings <ul style="list-style-type: none"> • Over-voltage shutdown can occur if settings are too high on 460V systems, causing an oscillation affect • Lower threshold level and retry
Stays in TEST mode	<ul style="list-style-type: none"> • Threshold way too high <ul style="list-style-type: none"> • Only appears to be in test mode • Can occur in 400V systems if RT is factory set for 585V

5.3. TECHNICAL HELP – BEFORE YOU CALL

If possible, please have the following information when calling for technical help:

- Exact model number of affected units
- Serial number of unit
- Name and model number of attached drives
- Name of original equipment supplier
- Brief description of the application
- The AC line to line voltage on all 3 phases
- The battery bank voltage
- The DC Bus voltage
- KVA rating of power source
- Source configuration Wye/Delta and grounding

This information will help us support you much more quickly. Please contact us at (615) 244-2825 or through www.bonitron.com

This page intentionally left blank

6. ENGINEERING DATA

6.1. RATINGS CHARTS

Table 6-1: Model S3534BR Ride-Thru Module Voltage Levels

AC INPUT VOLTAGE	OUTPUT DC BUS VOLTAGE LEVELS		INPUT DC BUS VOLTAGE LEVELS	
	THRESHOLD	NOMINAL	MINIMUM	MAXIMUM
115 VAC	145 VDC	160 VDC	100 VDC	145 VDC
230 VAC	285 VDC	320 VDC	200 VDC	285 VDC
380 VAC	485 VDC	565 VDC	350 VDC	500 VDC
460 VAC	585 VDC	640 VDC	400 VDC	585 VDC

Table 6-2: Typical Storage Bank Configurations

Not to replace manufacturer's recommendations.

SYSTEM AC VOLTAGE		230 VAC	380 VAC	460 VAC
Battery Bank	Nominal Voltage	240 VAC	420 VAC	480 VAC
	108VDC banks in series	0	4	0
	120VDC banks in series	2	0	4
	Full or Float Charge Voltage	270 VDC	473 VDC	540 VDC
	Equalize Voltage	277 VDC	484 VDC	554 VDC
	Discharged Voltage	200 VDC	350 VDC	400 VDC
M3534R	Threshold Voltage	285 VDC	485 VDC	585 VDC

6.2. FUSE/CIRCUIT BREAKER SIZING AND RATING

Table 6-3: Input Power Wiring Sizes and Fusing

SYSTEM KW	RIDE-THRU DC BUS CURRENT RATING	MIN. SOURCE FUSING SEMICONDUCTOR	RECOMMENDED FIELD WIRING SIZES	MCM EQUIVALENT WIRING SIZES
12 kW	20 A	30 A	14 AWG	4 kcmil
24 kW	40 A	60 A	8 AWG	16 kcmil

6.3. DIMENSIONS AND MECHANICAL DRAWINGS

Figure 6-1: S3534BR D80 Cabinet Dimensional Outline

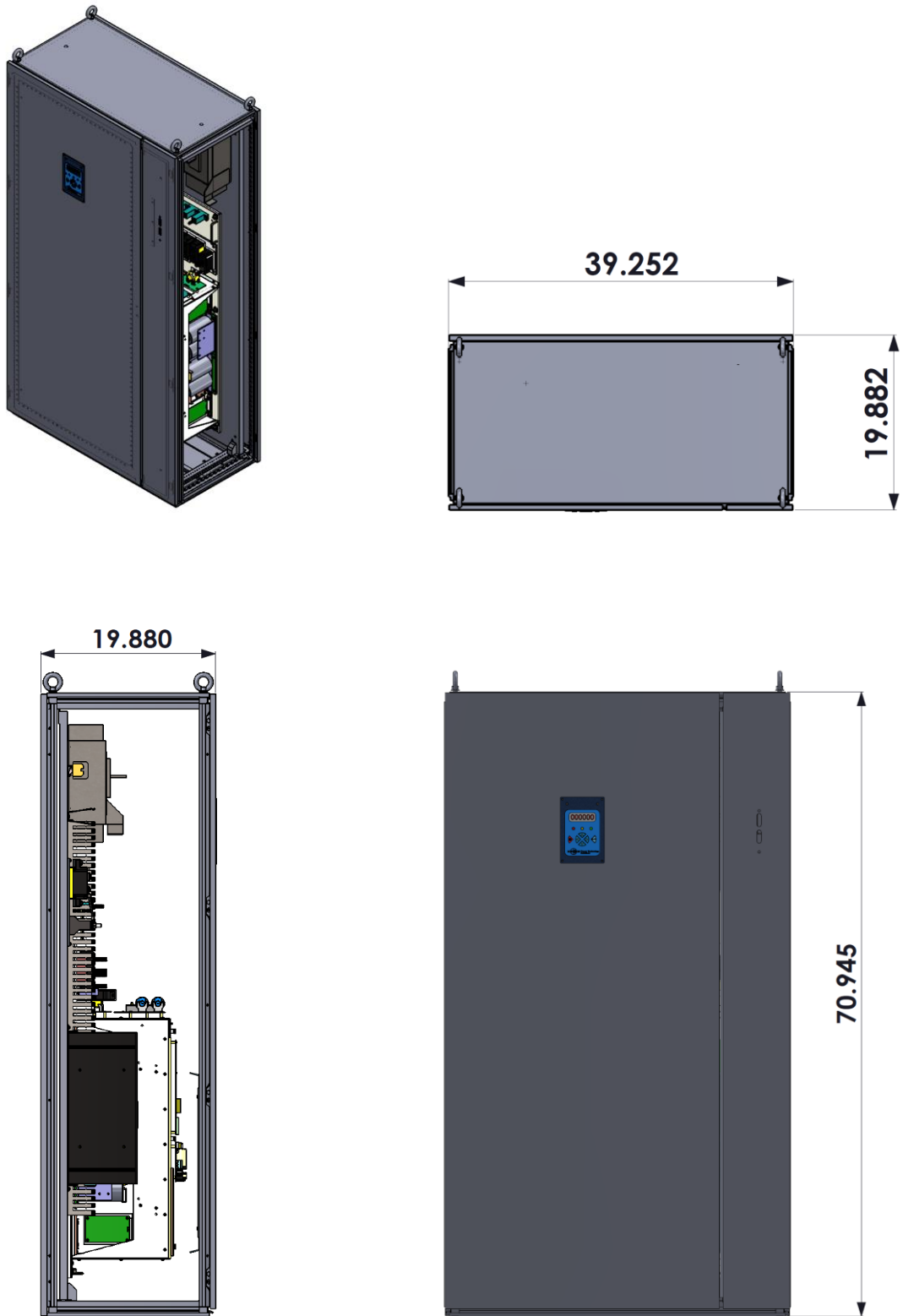

Figure 6-2: S3534BR D82 Cabinet Dimensional Outline

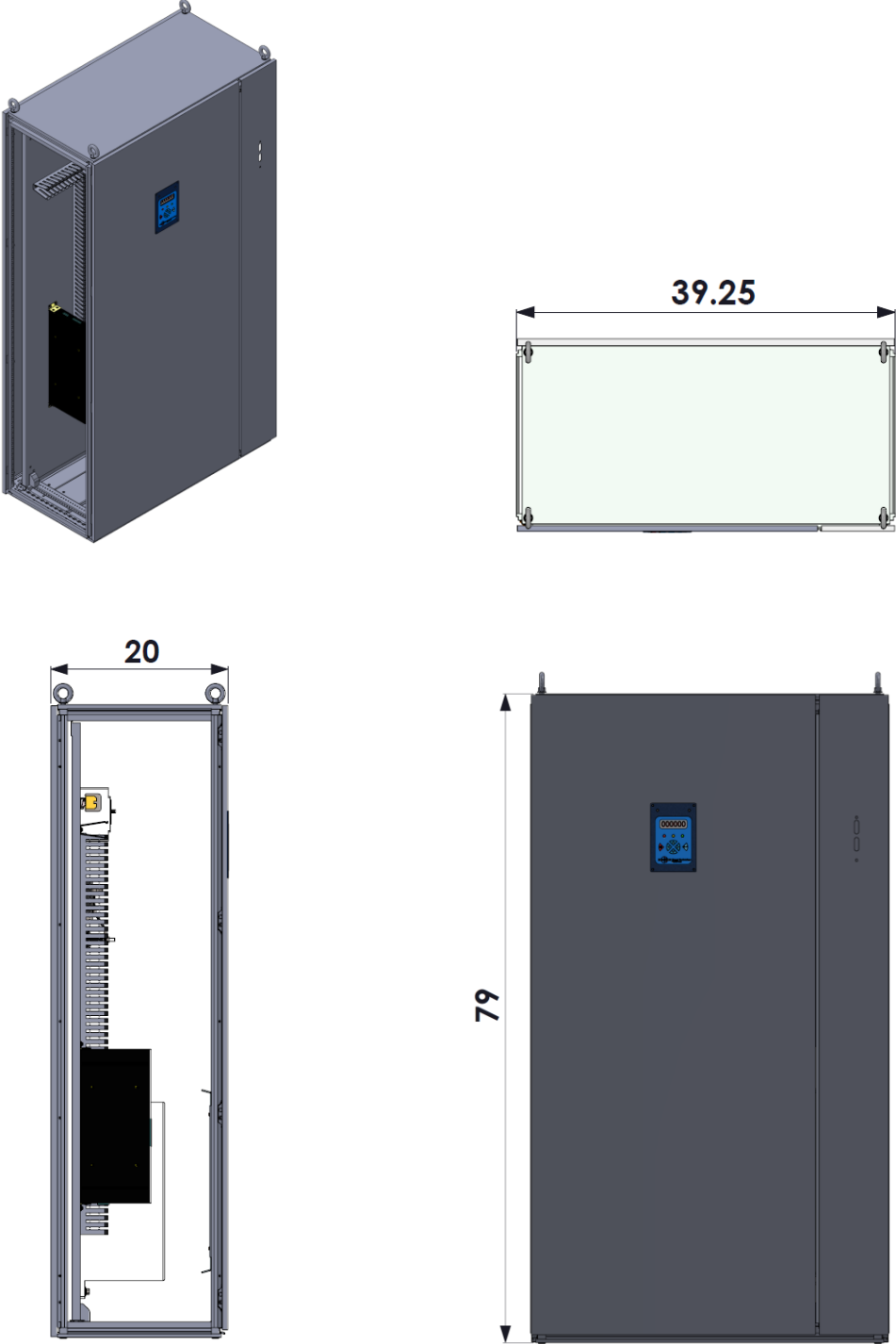

Figure 6-3: S3534BR E71 Cabinet Dimensional Outline

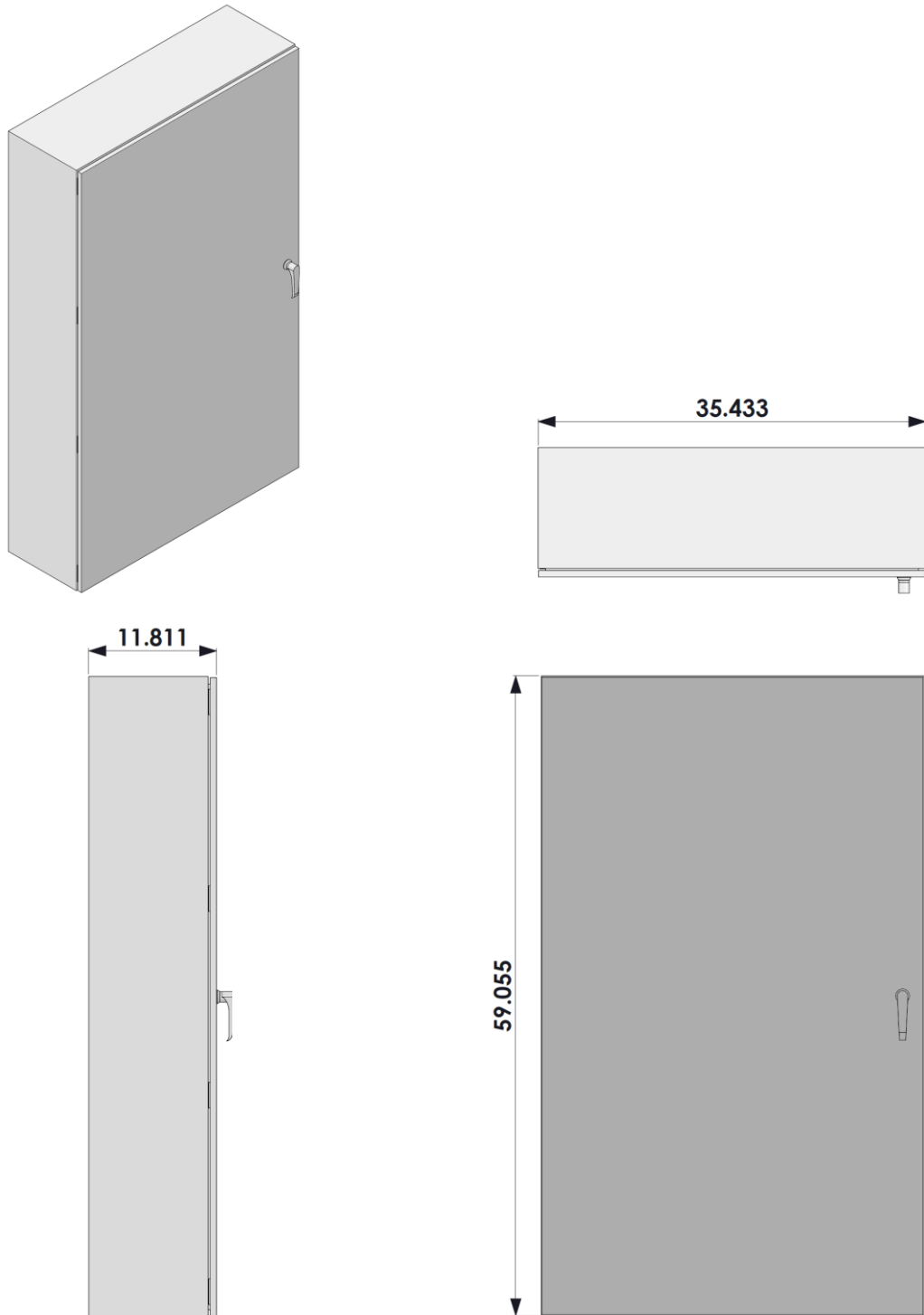
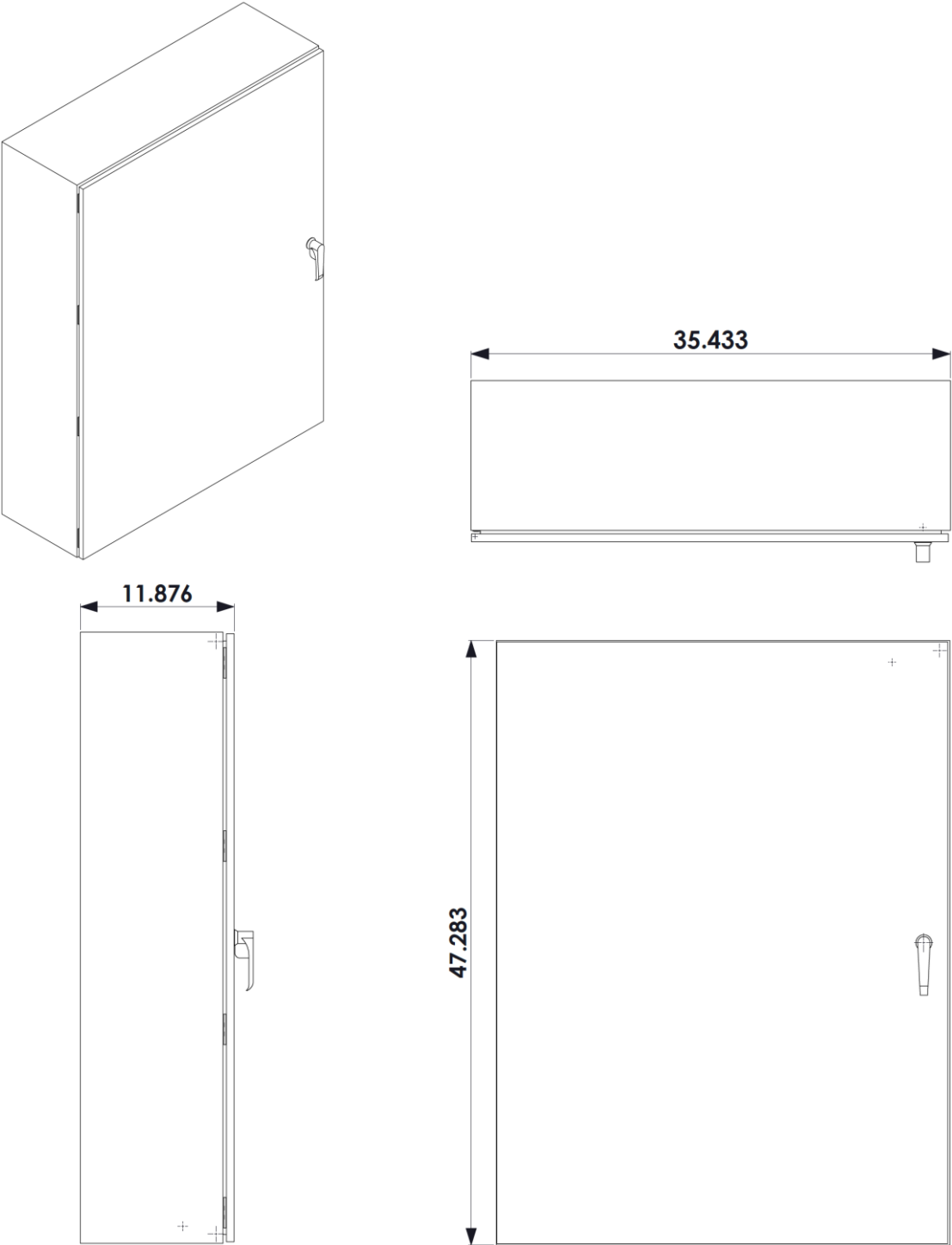

Figure 6-4: S3534BR E70Cabinet Dimensional Outline



This page intentionally left blank

This page intentionally left blank

This page intentionally left blank

This page intentionally left blank
