



Model M3675T

Braking Transistor

Customer Reference Manual

Bonitron, Inc.
Nashville, TN



An industry leader in providing solutions for AC drives.

ABOUT BONITRON

Bonitron designs and manufactures quality industrial electronics that improve the reliability of processes and variable frequency drives worldwide. With products in numerous industries, and an educated and experienced team of engineers, Bonitron has seen thousands of products engineered since 1962 and welcomes custom applications.

With engineering, production, and testing all in the same facility, Bonitron is able to ensure its products are of the utmost quality and ready to be applied to your application.

The Bonitron engineering team has the background and expertise necessary to design, develop, and manufacture the quality industrial electronic systems demanded in today's market. A strong academic background supported by continuing education is complemented by many years of hands-on field experience. A clear advantage Bonitron has over many competitors is combined on-site engineering labs and manufacturing facilities, which allows the engineering team to have immediate access to testing and manufacturing. This not only saves time during prototype development, but also is essential to providing only the highest quality products.

The sales and marketing teams work closely with engineering to provide up-to-date information and provide remarkable customer support to make sure you receive the best solution for your application. Thanks to this combination of quality products and superior customer support, Bonitron has products installed in critical applications worldwide.

AC DRIVE OPTIONS

In 1975, Bonitron began working with AC inverter drive specialists at synthetic fiber plants to develop speed control systems that could be interfaced with their plant process computers. Ever since, Bonitron has developed AC drive options that solve application issues associated with modern AC variable frequency drives and aid in reducing drive faults. Below is a sampling of Bonitron's current product offering.

WORLD CLASS PRODUCTS

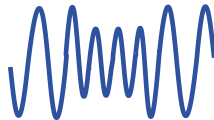

Undervoltage Solutions
Uninterruptible Power for Drives
(DC Bus Ride-Thru)
Voltage Regulators
Chargers and Dischargers
Energy Storage

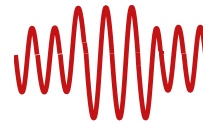

Overvoltage Solutions
Braking Transistors
Braking Resistors
Transistor/Resistor Combo
Line Regeneration
Dynamic Braking for Servo Drives



Common Bus Solutions
Single Phase Power Supplies
3-Phase Power Supplies
Common Bus Diodes



Portable Maintenance Solutions
Capacitor Formers
Capacitor Testers



Power Quality Solutions
12 and 18 Pulse Kits



Green Solutions
Line Regeneration

This page intentionally left blank.

1. INTRODUCTION.....	7
1.1. Who Should Use.....	7
1.2. Purpose and Scope.....	7
1.3. Manual Version and Change Record.....	7
Figure 1-1: Model M3675T.....	7
2. PRODUCT DESCRIPTION.....	9
2.1. Related Products.....	9
2.2. Part Number Breakdown.....	9
Figure 2-1: Example of M3575T Part Number Breakdown.....	9
Table 2-1: Control Voltage Rating Chart.....	10
2.3. General Specifications.....	10
Table 2-2: General Specifications Chart.....	10
2.4. General Precautions and Safety Warnings.....	11
3. INSTALLATION INSTRUCTIONS.....	13
3.1. Environment.....	13
3.2. Unpacking.....	13
3.3. Mounting.....	13
3.4. Wiring and Customer Connections.....	13
3.4.1. Power Wiring.....	13
Table 3-1: Power Wiring Specifications.....	14
3.5. Typical Configuration.....	14
Figure 3-1: Typical Chassis Interconnection Diagram.....	14
4. OPERATION.....	15
4.1. Functional Description.....	15
Table 4-1: Turn-On and Turn-Off Setpoints.....	15
4.2. Features.....	15
4.2.1. Indicators.....	15
5. MAINTENANCE AND TROUBLESHOOTING.....	17
5.1. Troubleshooting.....	17
5.1.1. Green dc bus power led does not come on.....	17
5.1.2. Red active braking led stays on or flashes during motoring operation.....	17
5.1.3. Drive trips on over-voltage or self-limits its decel rate.....	17
6. ENGINEERING DATA.....	19
6.1. Ratings Chart.....	19
Table 6-1: Module Ratings.....	19
6.2. Dimensions and Mechanical Drawings.....	20
Figure 6-1: M3675T Chassis Dimensional Outline Drawing.....	20
NOTES.....	20

This page intentionally left blank.

1. INTRODUCTION

1.1. WHO SHOULD USE

This manual is intended for use by anyone who is responsible for integrating, installing, maintaining, troubleshooting, or using this equipment with any AC drive system.

Please keep this manual for future reference.

1.2. PURPOSE AND SCOPE

This manual is a user's guide for the Model 3675T Braking Transistor. It will provide the user with the necessary information to successfully install, integrate, and use the M3675T.

In the event of any conflict between this document and any publication and/or documentation related to the AC drive system, the latter shall have precedence.

1.3. MANUAL VERSION AND CHANGE RECORD

Minor format changes were added in Rev 02d.

Features were changed in Rev 02e.

Minor format changes were added in Rev 02f.

Voltage rating U was added in Rev 02g.

Updates to indicators were added in Rev 02h.

The manual template was updated in Rev 02i.

Figure 1-1: Model M3675T



This page intentionally left blank.

2. PRODUCT DESCRIPTION

The need for braking control occurs in applications where the frequency of an AC motor at times exceeds that of the variable frequency drive controlling it. When this happens, the motor acts as a generator. The energy produced in these circumstances may cause the drive to trip on an over-voltage condition or cause the motor to build up heat or run with an excessively high volts/Hertz ratio. This regenerated energy must either be dissipated or returned to the power line. For applications where this condition occurs infrequently, dissipating the energy as heat through a Braking Transistor can be the most cost-effective solution.

The Model M3675T series of braking products is designed to provide dynamic braking control for applications utilizing a standard AC drive with a fixed DC bus. These modules have been designed for use with remotely mounted dynamic loads such as the M3675R-H100C or M3575R series of Dynamic Load Modules.

2.1. RELATED PRODUCTS

Like the M3675T, the Bonitron M3575T is a Standard Duty Braking Transistor that is rated for applications that require higher current. The M3575T is rated up to 600A peak at 20% duty cycle.

For applications that require high duty cycles, the Bonitron M3452 Heavy Duty Braking Transistor is rated for continuous duty.

The M3575R series of Dynamic Load Modules are available for use with the M3675T Braking Transistors or with the drive's integral braking control module.

2.2. PART NUMBER BREAKDOWN

Figure 2-1: Example of M3575T Part Number Breakdown

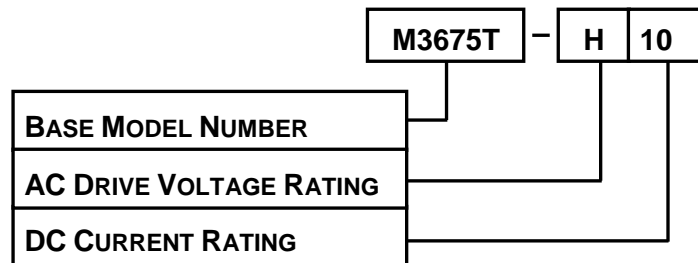

BASE MODEL NUMBER

The Base Model Number, M3675T, indicates that the unit incorporates the braking transistor and its control circuitry only. An external braking resistor is required for proper function of the braking module.

AC DRIVE VOLTAGE RATING

The AC Voltage Rating of the braking unit should match the input AC line voltage to the AC drive used with the braking module. The AC Drive Voltage is indicated by a code letter.

Table 2-1: Control Voltage Rating Chart

RATING CODE	LINE VOLTAGE INPUT
U	115 VAC
L	230 VAC
E	380 VAC
H	460 VAC

DC CURRENT RATING:

The DC Current Rating indicates the maximum DC current level safely handled by the braking unit. All M3675T modules are rated for a maximum of 10 Amps DC at 20% duty cycle.

2.3. GENERAL SPECIFICATIONS

Table 2-2: General Specifications Chart

PARAMETER	SPECIFICATION
Adjustments	Factory calibrated – no field adjustments necessary
Connections	Drive DC Bus Resistors
Enclosure	TYPE-1
Panel Indicators	DC Bus Active Braking
Braking Current	10 Amps DC maximum
Peak Horsepower	2.5 hp (for 115VAC drives) 5.0 hp (for 230VAC drives) 7.5 hp (for 380VAC drives) 10.0 hp (for 460VAC drives)
Duty Cycle	20% Maximum braking
Maximum On-Time	15 seconds
Storage Temp	-20°C to +65°C
Humidity	Below 90% non-condensing
Atmosphere	Free of corrosive gas and dust

2.4. GENERAL PRECAUTIONS AND SAFETY WARNINGS



- **HIGH VOLTAGES MAY BE PRESENT!**
- **FAILURE TO HEED THESE WARNINGS MAY RESULT IN SERIOUS BODILY INJURY OR DEATH!**



- **THIS PRODUCT GENERATES HEAT DURING OPERATION.**
- **THIS PRODUCT SHOULD BE INSTALLED ACCORDINGLY ON NON-FLAMMABLE SURFACES WITH CLEARANCES OF AT LEAST TWO INCHES IN ALL DIRECTIONS.**
- **NO USER-SERVICEABLE PARTS ARE CONTAINED WITHIN THIS PRODUCT. INOPERABLE UNITS SHOULD BE REPLACED OR RETURNED FOR EVALUATION AND/OR REPAIR BY QUALIFIED TECHNICIANS.**
- **BEFORE ATTEMPTING INSTALLATION OR REMOVAL OF THIS PRODUCT, BE SURE TO REVIEW ALL DRIVE AND/OR RESISTIVE LOAD DOCUMENTATION FOR PERTINENT SAFETY PRECAUTIONS.**
- **INSTALLATION AND/OR REMOVAL OF THIS PRODUCT SHOULD ONLY BE ACCOMPLISHED BY A QUALIFIED ELECTRICIAN IN ACCORDANCE WITH NATIONAL ELECTRICAL CODE OR EQUIVALENT REGULATIONS.**

ANY QUESTIONS AS TO APPLICATION, INSTALLATION OR SERVICE SAFETY SHOULD BE DIRECTED TO THE EQUIPMENT SUPPLIER.

This page intentionally left blank.

3. INSTALLATION INSTRUCTIONS



Installation and/or removal of this product should only be performed by a qualified electrician in accordance with National Electrical Code or local codes and regulations.

Proper installation of the Model M3675T Braking Transistor should be accomplished following the steps outlined below. Be sure to refer to your AC drive's instruction manual as you perform these steps. Please direct all installation inquiries that may arise during the installation and startup of this braking product to your supplier or system integrator.

3.1. ENVIRONMENT

The installation site for the module should be chosen with several considerations in mind:

- The mounting surface must be non-flammable, as the unit may generate high ambient temperatures during typical operation.
- The unit will require a minimum clearance of two inches in all directions around it.
- The unit will require adequate protection from the elements.

3.2. UNPACKING

Upon receipt of this product, please verify that the product received matches the product that was ordered and that there is no obvious physical damage to the unit. If the wrong product was received or the product is damaged in any way, please contact the supplier from which the product was purchased.

3.3. MOUNTING

Once the installation site has been selected as outlined above, the unit should be mounted in place using two ¼ inch diameter bolts or studs. Refer to Figure 6-1 to determine the correct mounting dimensions for your unit.

3.4. WIRING AND CUSTOMER CONNECTIONS

This section provides information pertaining to the field connection of the DC bus inputs to the M3675T Braking Transistor. Actual connection points and terminal numbers for the AC drive module will be found in the documentation provided with the drive. **Be sure to review all pertinent drive and system documentation as well as the power wiring information in Section 3.4.1 before proceeding.**

3.4.1. POWER WIRING



Only qualified electricians should perform and maintain the interconnection wiring of this product. All wiring should be done in accordance with local codes.



DC bus polarity must be observed! Connecting the DC bus with the polarity reversed will cause damage to the equipment!

For the maximum wire size accepted by the individual field connection terminals, refer to Table 3-1: Power Wiring Specifications. Wire types and

sizes should be chosen in accordance with national and local electrical codes to meet the voltage and current levels present for your application.

Minimum load resistance requirements listed in Table 6-1: Module Ratings in the Engineering Section of this manual **MUST** be followed when selecting a dynamic load for use with the M3675T unit.

Figure 3-1 shows a typical interconnection of the M3675T with the M3575R Resistor Module. For interconnection with other load modules, refer to the documentation supplied with them.

Table 3-1: Power Wiring Specifications

TERMINAL	MIN WIRE AWG	MAX WIRE AWG	TORQUE
DC+, DC-, RES+, RES-	16	12	8 lb-in
Ground	16	12	8 lb-in

3.5. TYPICAL CONFIGURATION

Figure 3-1: Typical Chassis Interconnection Diagram

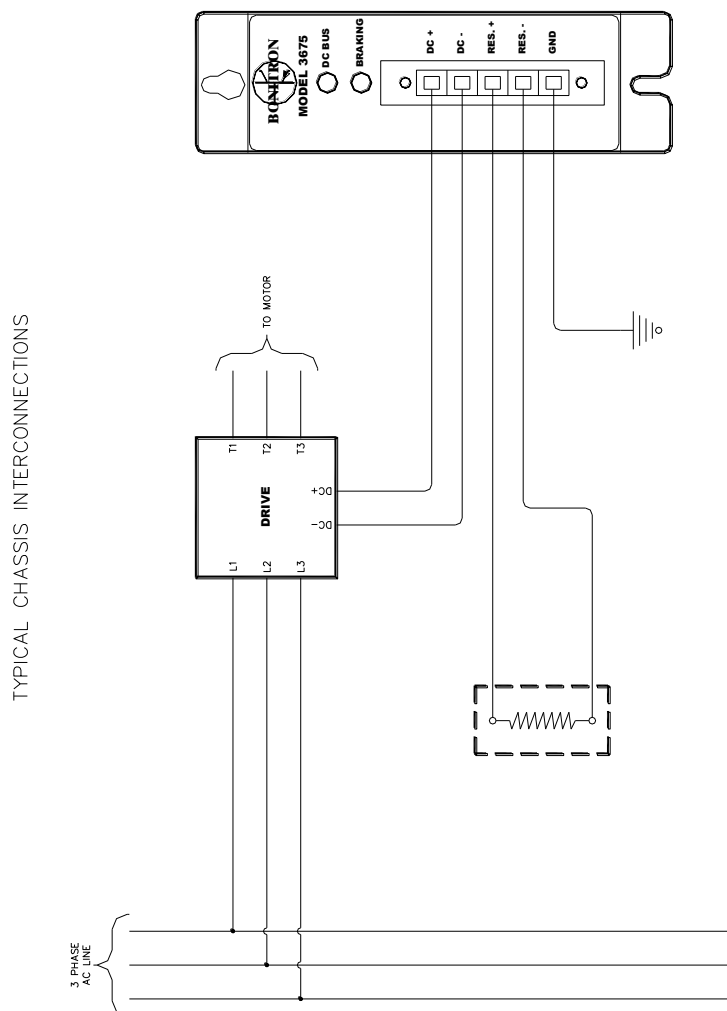

4. OPERATION

4.1. FUNCTIONAL DESCRIPTION

The M3675T Module controls the bus voltage of a variable frequency drive by transferring energy to a resistor.

When the drive's DC bus voltage exceeds a fixed setpoint, the Braking Transistor's control electronics turns on an IGBT transistor connecting a dynamic load across the DC bus. When the DC bus drops below another threshold, the IGBT turns off.

Table 4-1: Turn-On and Turn-Off Setpoints

RATING CODE	LINE VOLTAGE INPUT	TURN-ON SETPOINT	TURN-OFF SETPOINT
U	115VAC	190VDC	180VDC
L	230VAC	375VDC	350VDC
E	380VAC	620VDC	600VDC
H	460VAC	750VDC	725VDC

4.2. FEATURES

4.2.1. INDICATORS

4.2.1.1. DC BUS

The DC Bus indicator illuminates when the voltage between the DC+ and DC- terminals is greater than 50VDC.



Do not use this light as an indication that the DC bus is safe to work on! Always check the DC bus with a working voltmeter before servicing equipment, as the DC bus light may be broken!

4.2.1.2. ACTIVE BRAKING

This indicator illuminates when the chopper IGBT is on. When the drive is idle, this light should not be on. During braking, this light will be on or flashing, depending on the amount of braking energy.

This light will also be on if the Bus Discharge input is active.

This page intentionally left blank.

5. MAINTENANCE AND TROUBLESHOOTING

5.1. TROUBLESHOOTING

If a problem occurs on start-up or during normal operation, refer to the problems described below. If a problem persists after following the steps below, contact the product supplier or your system integrator for assistance.

Repairs or modifications to this equipment are to be performed by Bonitron approved personnel only. Any repair or modification to this equipment by personnel not approved by Bonitron will void any warranty remaining on this unit.

5.1.1. GREEN DC BUS POWER LED DOES NOT COME ON

Ensure proper DC Bus voltage at input terminals to the unit. If proper DC Bus voltage is present, return unit for repair or replace unit.

5.1.2. RED ACTIVE BRAKING LED STAYS ON OR FLASHES DURING MOTORING OPERATION

Ensure that the voltage rating of M3675T is the same as the AC Drive. If the voltage rating is the same, ensure that the line voltage to the AC Drive is correct. If line voltage is abnormally high or low, the unit may require special calibration adjustments. Contact the product supplier or your system integrator for assistance. If correct line voltage is present on the AC Drive and the M3675T module is rated for the same line voltage as the AC Drive, return unit for repair or replace unit.

5.1.3. DRIVE TRIPS ON OVER-VOLTAGE OR SELF-LIMITS ITS DECEL RATE

Ensure that the Green DC Bus Power LED is **ON** (see above).

Ensure that the proper dynamic load value is connected to the M3675T unit and that the maximum current rating is not exceeded.

Most AC drives are capable of 150-200% output. If the AC Drive continues to trip and the application has been thoroughly reviewed, contact Bonitron.

This page intentionally left blank.

6. ENGINEERING DATA

6.1. RATINGS CHART

See Table 6-1 below for the ratings for all M3675T modules currently available. Units are rated for 20% duty or 2A RMS. If your module is not listed below, please contact your supplier or systems integrator for this information.

Table 6-1: Module Ratings

PART NUMBER	DRIVE VOLTAGE	MAX DC AMPS	MAX BRAKING	MINIMUM LOAD
M3675T-U10	115VAC	10A	2.5hp	19Ω
M3675T-L10	230VAC	10A	5.0hp	38Ω
M3675T-E10	380VAC	10A	7.5hp	62Ω
M3675T-H10	460VAC	10A	10.0hp	75Ω

6.2. DIMENSIONS AND MECHANICAL DRAWINGS

Figure 6-1: M3675T Chassis Dimensional Outline Drawing

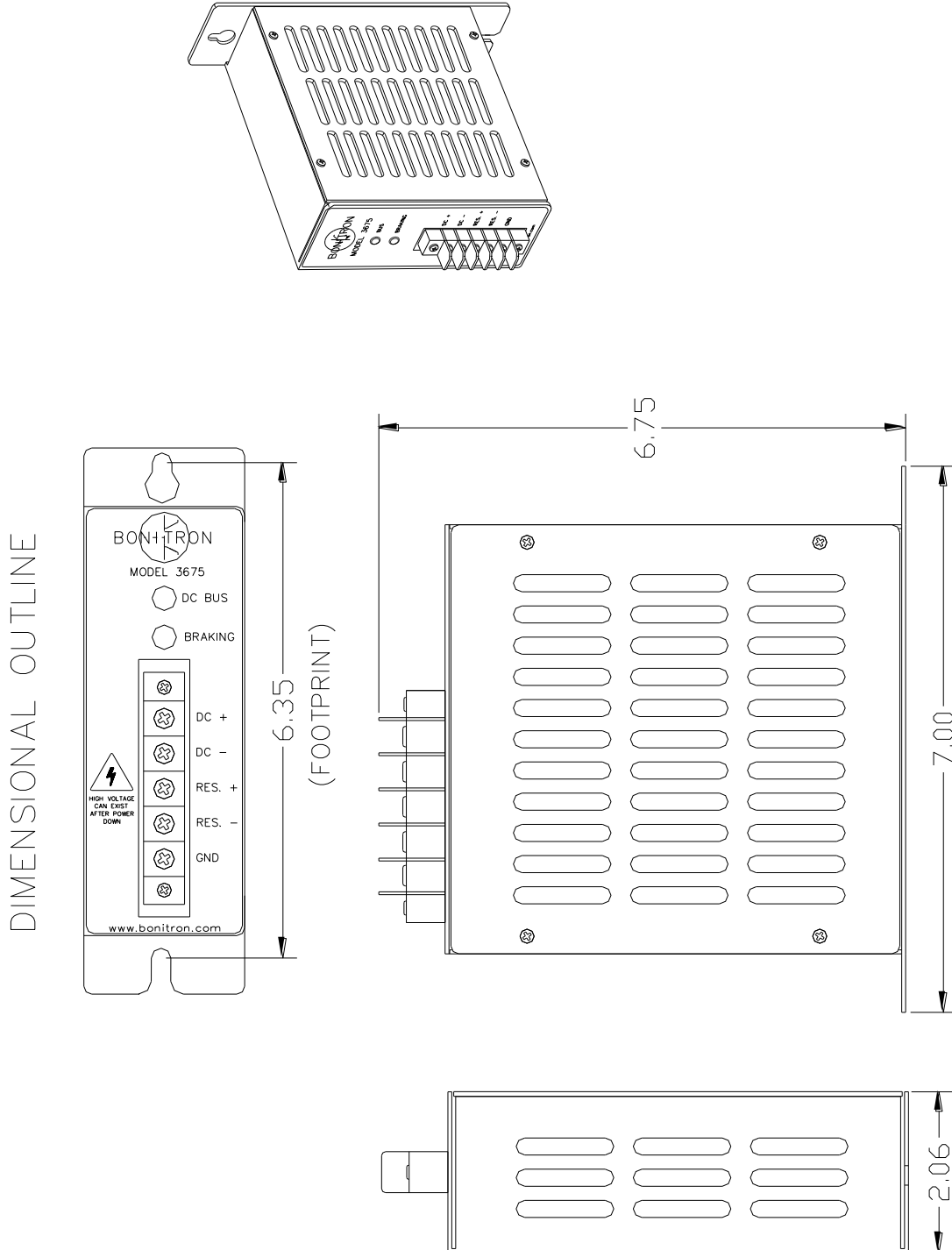

This page intentionally left blank.
