



Solutions for AC Drives

Model M3645P

Regenerative DC Bus Power Supply

Customer Reference Manual

Bonitron, Inc.
Nashville, TN



An industry leader in providing solutions for AC drives.

ABOUT BONITRON

Bonitron designs and manufactures quality industrial electronics that improve the reliability of processes and variable frequency drives worldwide. With products in numerous industries, and an educated and experienced team of engineers, Bonitron has seen thousands of products engineered since 1962 and welcomes custom applications.

With engineering, production, and testing all in the same facility, Bonitron is able to ensure its products are of the utmost quality and ready to be applied to your application.

The Bonitron engineering team has the background and expertise necessary to design, develop, and manufacture the quality industrial electronic systems demanded in today's market. A strong academic background supported by continuing education is complemented by many years of hands-on field experience. A clear advantage Bonitron has over many competitors is combined on-site engineering labs and manufacturing facilities, which allows the engineering team to have immediate access to testing and manufacturing. This not only saves time during prototype development, but also is essential to providing only the highest quality products.

The sales and marketing teams work closely with engineering to provide up-to-date information and provide remarkable customer support to make sure you receive the best solution for your application. Thanks to this combination of quality products and superior customer support, Bonitron has products installed in critical applications worldwide.

AC DRIVE OPTIONS

In 1975, Bonitron began working with AC inverter drive specialists at synthetic fiber plants to develop speed control systems that could be interfaced with their plant process computers. Ever since, Bonitron has developed AC drive options that solve application issues associated with modern AC variable frequency drives and aid in reducing drive faults. Below is a sampling of Bonitron's current product offering.

WORLD CLASS PRODUCTS

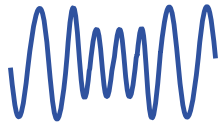

Undervoltage Solutions
Uninterruptible Power for Drives
(DC Bus Ride-Thru)
Voltage Regulators
Chargers and Dischargers
Energy Storage

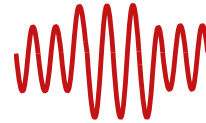

Overvoltage Solutions
Braking Transistors
Braking Resistors
Transistor/Resistor Combo
Line Regeneration
Dynamic Braking for Servo Drives

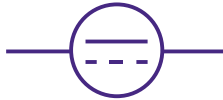

Common Bus Solutions
Single Phase Power Supplies
3-Phase Power Supplies
Common Bus Diodes



Portable Maintenance Solutions
Capacitor Formers
Capacitor Testers

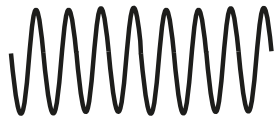

Power Quality Solutions
12 and 18 Pulse Kits



Green Solutions
Line Regeneration

1. INTRODUCTION	7
1.1. Who should use	7
1.2. Purpose and Scope.....	7
1.3. Manual Version and Change Record.....	7
Figure 1-1: Typical M3645P Regenerative DC Bus Power Supply	8
1.4. Symbol Conventions Used in this Manual and on Equipment	9
2. PRODUCT DESCRIPTION	10
2.1. Related Products	10
2.2. Part Number Breakdown	11
Figure 2-1: Example of M3645P Part Number Breakdown	11
Table 2-1: Voltage Ratings	11
Table 2-2: Module Identifier	12
Table 2-3: Chassis Styles	12
Table 2-4: Option Codes	12
2.3. General Specifications Chart	13
Table 2-5: General Specifications	13
2.4. General Precautions and Safety Warnings	14
3. INSTALLATION INSTRUCTIONS	16
3.1. Environment	16
3.2. Unpacking.....	16
3.3. Mounting	16
3.3.1. M3645P DC Bus Regenerative Power Supply	16
Figure 3-1: M3645P Mounting Orientation	17
3.3.2. M3645 M15 Line Reactor Mounting.....	18
3.3.3. KIT 3645DD, External Display Mounting	18
3.4. Wiring and Customer Connections.....	18
3.4.1. Power Wiring.....	18
Table 3-1: Transformer Ratings	19
Table 3-2: Power Terminal Specifications - 30 Amp Unit – M10 Chassis	20
Table 3-3: Power Terminal Specifications - 50 Amp Unit – M11 Chassis	20
Table 3-4: Power Terminal Specifications - 100 Amp Unit – M12 Chassis	20
Figure 3-2: Power Connections.....	21
Figure 3-3: Connection Locations.....	21
Table 3-5: Power Terminal Specifications – 150A, 225A, and 300A Unit – M15 Chassis	22
Figure 3-4: M3645P 150A, 225A, and 300A Power Connections	22
Figure 3-5: M3645P 150A, 225A, and 300A Connection Locations	23
Table 3-6: Power Terminal Specifications – 150A, 225A, and 300A Unit – Line Reactor	24
Figure 3-6: M3645 150A, 225A, and 300A Reactor Connections	24
3.4.2. I/O Wiring.....	25
Table 3-7: I/O Terminal Specifications.....	25
Figure 3-7: M3645P 30A, 50A, 100A User I/O Connections	26
Figure 3-8: M3645P Enable Input Using Internal Power Supply.....	27
Figure 3-9: M3645P Enable Input Using External Power Supply	27
3.5. Typical Configurations	28
Figure 3-10: M3645P 30A, 50A, 100A Power Wiring	29
Figure 3-11: M3645P 150A, 225A, and 300A Power Wiring.....	30
Figure 3-12: M3645P Multiple Drives Field Wiring Diagram.....	31
Figure 3-13: M3645P Connection with KIT 3645DD, External Panel Mounted Display.....	32
Figure 3-14: M3645P Connection with KIT 3645DD, External Display Wiring.....	33

4. OPERATION.....	34
4.1. Functional Description	34
4.2. Features.....	34
4.2.1. Digital Display	34
4.2.2. LEDs	34
4.2.3. Buttons	34
4.3. Digital Display Operation.....	35
4.3.1. Metering Screen	35
4.3.2. Energy Records Screen	35
4.3.3. Reset Energy Records Screen	35
4.3.4. Faults Screen.....	35
4.3.5. Fault Records Screen	35
Figure 4-1: M3645P Screen Tree	35
4.4. Faults	36
Table 4-1: Blink Codes	36
4.4.1. Feedback Undervoltage	36
4.4.2. Overtemperature	36
4.4.3. DC Overvoltage	37
4.4.4. Differential Overvoltage	37
4.4.5. Sync Loss.....	37
4.4.6. IGBT Driver.....	37
4.4.7. Phase 1-3 Overcurrent	37
4.4.8. Phase Loss.....	37
4.4.9. DC Undervoltage	37
4.4.10. Regen Power-On/Precharge Not Complete	38
4.4.11. Frequency Detect Failure.....	38
4.5. Input / Output Connections.....	38
4.5.1. Local I/O +24V Supply- TB2-1 & TB2-5	38
4.5.2. Enable Input - TB2-2	38
4.5.3. Fault Recall Input -TB2-3	38
4.5.4. Input COM -TB2-4	38
4.5.5. Ready Output - TB2-6	38
4.5.6. Overtemperature Output/Regen Active - TB2-7.....	39
4.5.7. Output COM - TB2-8	39
4.6. Startup.....	39
4.6.1. Pre-power Checks.....	39
4.6.2. Startup Procedure and Checks	39
4.6.3. Cooling Fan.....	39
5. MAINTENANCE AND TROUBLESHOOTING.....	41
5.1. Periodic Testing.....	41
5.2. Maintenance Items.....	41
5.3. Troubleshooting.....	41
5.3.1. POWER LED is not on, or Digital Display is not active:.....	41
5.3.2. READY output will not close	41
5.3.3. Unit will not respond to ENABLE command.....	41
5.3.4. Drive trips on DC Bus Overvoltage during braking	41
5.3.5. Feedback Undervoltage	42
5.3.6. Overtemperature	42
5.3.7. DC overvoltage.....	42
5.3.8. Differential Overvoltage	43

5.3.9.	Sync Loss.....	43
5.3.10.	IGBT Driver.....	43
5.3.11.	Phase Overcurrent.....	43
5.3.12.	Phase Loss.....	43
5.3.13.	DC Undervoltage	43
5.3.14.	Regen Power-On/Precharge Not Complete	43
5.3.15.	Frequency Detect Failure.....	44
5.3.16.	Technical Help – Before you contact us	44
6.	ENGINEERING DATA.....	45
6.1.	Ratings Charts.....	45
	Table 6-1: Ratings and Specifications – 230 - 240VAC	45
	Table 6-2: Ratings and Specifications – 380 - 415VAC	45
	Table 6-3: Ratings and Specifications – 460 - 480VAC	45
	Table 6-4: Ratings and Specifications – 575 - 600VAC	46
6.2.	Derating Parallel Units	46
	Table 6-5: Derating Regens in Parallel	46
6.3.	Watt Loss.....	46
6.4.	Certifications and RoHS.....	46
6.5.	Fuse Selection.....	48
	Table 6-6: Fuse Current Rating Requirements.....	48
	Table 6-7: Fuse Voltage Rating Requirements	48
6.6.	Dimensions and Mechanical Drawings	49
	Figure 6-1: M3645P M10 Chassis Dimensional Outline	49
	Figure 6-2: M3645P M11 Chassis Dimensional Outline	50
	Figure 6-3: M3645P M12 Chassis Dimensional Outline	51
	Figure 6-4: M3645P M15 Dimensional Outline	52
	Figure 6-5: M3645 M15 Line Reactor Dimensional Outline	53
	Figure 6-6: KIT 3645DD, External Display Dimensional Outline.....	54
6.7.	Block Diagram.....	55
	Figure 6-7: Typical Customer Application.....	55
7.	APPENDIX.....	56
7.1.	Application Notes	56
	7.1.1. Sizing the Line Regeneration Unit.....	56
	7.1.2. Calculating Energy Savings.....	57

1. INTRODUCTION

1.1. WHO SHOULD USE

This manual is intended for use by anyone who is responsible for integrating, installing, maintaining, troubleshooting, or using this equipment with any AC drive system. Please keep this manual for future reference.

1.2. PURPOSE AND SCOPE

This manual is a user's guide for the model M3645P regenerative DC bus power supply. It provides you with the necessary information to successfully install and use the M3645P modules in your application.

In the event of any conflict between this document and any publication and/or documentation related to the application, the latter shall have precedence.

1.3. MANUAL VERSION AND CHANGE RECORD

The initial release of the M3645P manual is Rev 00a.

Update to Section 7 on the sizing and energy savings in Rev 00b.

Updated to include KIT 3645DD and M15 frame size in Rev 00c.

Update to Figure 3-9, Sections 6.2, and 6.6 in Rev 00d.

Precharge Option was added in Rev 00e.

Figure 6-5 was updated in Rev 00f.

Section 6.1 was updated in Rev 00g.

Updated section 3 to include reactor information in Rev 00h.

Updated section 3.4 in rev 00i.

Updated Table 2-5 in Rev 00j.

Updated Section 7.1.1 in Rev 00k.

Updated Section 6.2 in Rev 00l.

Updated Section 2.3 table 2-5, section 3.4.2 and 4.5.6 in Rev 00m.

Updated Figure 3-11 in rev 00n.

Updated Figures 3-10, 3-11, and 3-12 in Rev 00p.







Updated Section 3.3.3.

Updated Current Rating under Section 2.2 in Rev 00r.

Figure 1-1: Typical M3645P Regenerative DC Bus Power Supply



1.4. SYMBOL CONVENTIONS USED IN THIS MANUAL AND ON EQUIPMENT

	<p>Earth Ground or Protective Earth</p>
	<p>AC Voltage</p>
	<p>DC Voltage</p>
 <p>DANGER!</p>	<p>DANGER: Electrical hazard - Identifies a statement that indicates a shock or electrocution hazard that must be avoided.</p>
 <p>DANGER!</p>	<p>DANGER: Identifies information about practices or circumstances that can lead to personal injury or death, property damage, or economic loss.</p>
 <p>CAUTION!</p>	<p>CAUTION: Identifies information about practices or circumstances that can lead to property damage, or economic loss. Attentions help you identify a potential hazard, avoid a hazard, and recognize the consequences.</p>
 <p>CAUTION!</p>	<p>CAUTION: Heat or burn hazard - Identifies a statement regarding heat production or a burn hazard that should be avoided.</p>

2. PRODUCT DESCRIPTION

Regenerated voltage occurs when the speed of the motor exceeds the set speed on the drive. This can be due to braking or an overhauling load. In applications with extended braking times, high horsepower, or where frequent regeneration occurs, the M3645P regenerative DC bus power supply is the economical solution for controlling regenerative voltage. While resistor solutions waste regenerated energy as heat, the Bonitron M3645P returns the regenerated energy back to the input AC line. M3645P also acts as a rectifier, supplying power to the drive bus during motoring.

The M3645P regenerative DC bus power supply synchronizes to the frequency of the incoming power line, allowing it to automatically adapt to 50Hz or 60Hz input. Under normal conditions, the M3645P rectifies the AC line and supplies power to the load. During a braking event, as the DC bus rises above the AC line peak, the M3645P redirects current from the DC bus into the AC line to limit the rise in bus voltage and prevent overvoltage faults. While regenerating the M3645P will automatically fold back in an overcurrent condition, or shut down in the event that unsafe conditions are detected.

With the optional digital display, the current status of the M3645P is shown and fault records are stored, along with a lifetime count of regenerative energy.

Up to two 100A M3645P units can be run in parallel for high-power applications.

2.1. RELATED PRODUCTS

COMMON BUS DIODES

- M3345CBM Sharing Diode

EXTERNAL PANEL MOUNTED DIGITAL DISPLAY

- KIT 3645DD External Display Kit (compatible only with “L” M3645P power supply)

BRAKING RESISTORS

- M3575R Standard Duty Braking Resistors (<30A)
- M3775R Various Duty Load Banks (<1600A)

BRAKING TRANSISTORS

- M3452 Heavy Duty Braking Transistor (<1600A)
- M3575T Standard Duty Braking Transistor (<600A)
- M3675T Low HP Braking Transistor (<10A)

THREE PHASE POWER SUPPLIES

- M3713DM Non-Regenerative Power Supply (<375A)
- M3713SC Non-Regenerative Power Supply with Precharge (<375A)

LINE REGEN

- M3545 Single Phase or Three Phase Line Regen (<15A)
- M3645 Heavy Duty Line Regen (<375A)

2.2. PART NUMBER BREAKDOWN

Figure 2-1: Example of M3645P Part Number Breakdown

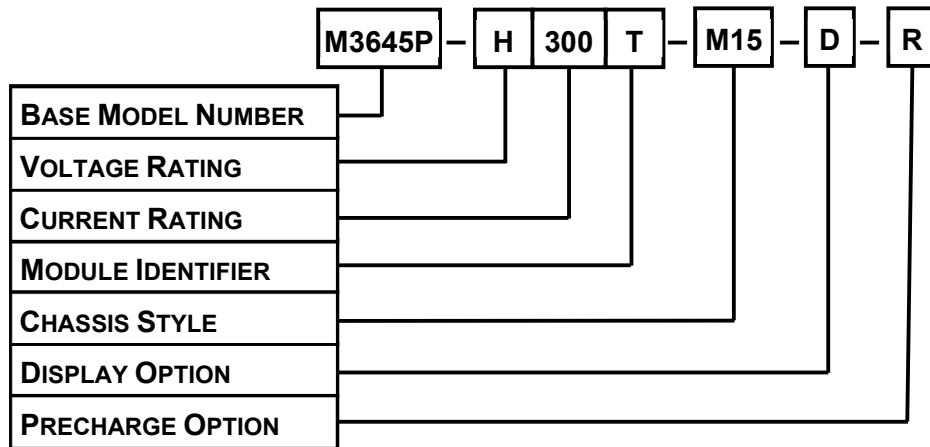

BASE MODEL NUMBER

The base model number for all regenerative DC bus power supply units is **M3645P**.

VOLTAGE RATING

A code letter represents the 3-phase AC line input voltage to the power supply module. The voltage rating must be selected for the system voltage that will be applied. See Table 2-1 for available voltage ratings.

Table 2-1: Voltage Ratings

RATING CODE	VOLTAGE
L	230 - 240VAC
E	380 - 415VAC
H	460 - 480VAC
C	575 - 600VAC

Note: C voltage class is only available for regens with current ratings of 100A or lower.

CURRENT RATING

A 3-digit number represents the maximum continuous DC current (Amps) the regen module can regenerate.

The 30A to 225A units are all capable of handling a 50% overload above this current rating for 60 seconds. The 300A unit is capable of a 25% overload above this current rating for 60 seconds.

MODULE IDENTIFIER

This single letter code is added to the model number to indicate if the line regen is made up of separate reactor and line regen modules. This module identifier is omitted in regens with current ratings of 30A, 50A, and 100A.

Both a line reactor module and a line regen module are required for 150A, 225A, and 300A models. A single letter code is used to designate the line reactor and the line regen.

Table 2-2: Module Identifier

CODE	MODEL	DESCRIPTION
R	M3645-x150R	Reactor Module
R	M3645-x225R	Reactor Module
R	M3645-x300R	Reactor Module
T	M3645P-x150T-M15	Line Regen Module
T	M3645P-x225T-M15	Line Regen Module
T	M3645P-x300T-M15	Line Regen Module

CHASSIS STYLE

The chassis style is determined by the current rating, and is represented by an alphanumeric code as defined in Table 2-3. See Section 6.5 for chassis mounting and dimensional outlines.

Table 2-3: Chassis Styles

CHASSIS CODE	CURRENT	DESCRIPTION	SIZE (H x W x D)
M10	30 A	Open Chassis	20.0" x 10.0" x 10.1"
M11	50 A	Open Chassis	22.0" x 11.3" x 10.6"
M12	100 A	Open Chassis	24.0" x 12.0" x 12.1"
M15	300 A	Open Chassis	26.0" x 13.9" x 11.1"
M15 Reactor	300 A	Open Chassis	17.9" x 18.8" x 15.2"

See Section 6.5 for chassis mounting and dimensional outlines.

DISPLAY

Two display options are available.

Table 2-4: Option Codes

OPTION CODE	DESCRIPTION
D	Digital Diagnostic Display
L	Basic LED Indicators

NOTE: The KIT 3645DD external display is only compatible with "L" versions of the M3645P regenerative DC bus power supply. Only a single display can be used for each M3645P. The M3645P is unable to power more than a single display.

PRECHARGE OPTION

The internal precharge option is designated by a single letter code **R**. When the precharge option is not included this code is omitted.

The internal precharge option allows the M3645P to precharge the connected VFD.

2.3. GENERAL SPECIFICATIONS CHART

Table 2-5: General Specifications

PARAMETER	SPECIFICATION		
AC Line Voltage	Voltage Rating 50 or 60 Hz	Voltage Min	Voltage Max
	L	207 VAC	253 VAC
	E	342 VAC	418 VAC
	H	414 VAC	506 VAC
	C	518 VAC	600 VAC
DC Input Current	<ul style="list-style-type: none"> • 30-300A, continuous • 150% of rating, 60 second overload for M10, M11, M12 chassis • 125% of rating, 60 second overload for M15 chassis 		
Control Voltage	<ul style="list-style-type: none"> • Internal 		
Short Circuit Current Rating (SCCR)	<ul style="list-style-type: none"> • Suitable for use on a circuit capable of delivering not more than 65,000 RMS symmetrical amperes, at the rated voltage when protected by the recommended fuses. DC fusing is not required. 		
Indicators	<ul style="list-style-type: none"> • Power • Regen • Fault • Optional 4 line character display 		
Inputs	<ul style="list-style-type: none"> • Enable 24VDC - 5mA • Fault Recall 24VDC - 5mA 		
Outputs	<ul style="list-style-type: none"> • Ready 200VDC - 100 mA 		
Operating Temp	<ul style="list-style-type: none"> • 0 to +40°C 		
Storage Temp	<ul style="list-style-type: none"> • -20° to +65°C 		
Humidity	<ul style="list-style-type: none"> • Below 90%, non-condensing 		
Atmosphere	<ul style="list-style-type: none"> • Free of corrosive gas or conductive dust 		
Altitude	<ul style="list-style-type: none"> • Up to 1000 Meters (3000 feet) above sea level* 		

*Units must be derated by 2% for every 300 meters (1000 feet) above 1000 meters (3000 feet) sea level.

2.4. GENERAL PRECAUTIONS AND SAFETY WARNINGS



- **HIGH VOLTAGES MAY BE PRESENT!**
- **NEVER ATTEMPT TO OPERATE THIS PRODUCT WITH THE ACCESS DOORS OR COVERS OPENED!**
- **NEVER ATTEMPT TO SERVICE THIS PRODUCT WITHOUT FIRST DISCONNECTING POWER TO AND FROM THE UNIT!**
- **FAILURE TO HEED THESE WARNINGS MAY RESULT IN SERIOUS BODILY INJURY OR DEATH!**



- **THIS PRODUCT WILL GENERATE HIGH AMBIENT TEMPERATURES DURING OPERATION.**
- **THIS PRODUCT SHOULD BE INSTALLED ON A NON-FLAMMABLE SURFACE WITH CLEARANCES OF AT LEAST TWO INCHES IN ALL DIRECTIONS.**
- **ALWAYS ALLOW AMPLE TIME FOR THE UNIT TO COOL BEFORE ATTEMPTING SERVICE ON THIS PRODUCT.**
- **BEFORE ATTEMPTING INSTALLATION OR REMOVAL OF THIS PRODUCT, BE SURE TO REVIEW ALL DRIVE AND/OR RESISTIVE LOAD DOCUMENTATION FOR PERTINENT SAFETY PRECAUTIONS.**
- **INSTALLATION AND/OR REMOVAL OF THIS PRODUCT SHOULD ONLY BE ACCOMPLISHED BY A QUALIFIED ELECTRICIAN IN ACCORDANCE WITH NATIONAL ELECTRICAL CODE OR EQUIVALENT REGULATIONS.**

ANY QUESTIONS AS TO APPLICATION, INSTALLATION OR SERVICE SAFETY SHOULD BE DIRECTED TO THE EQUIPMENT SUPPLIER.

This page intentionally left blank

3. INSTALLATION INSTRUCTIONS



Installation and/or removal of this product should only be performed by a qualified electrician in accordance with National Electrical Code or local codes and regulations.

Proper installation of the M3645P DC bus power supply modules should be executed following the steps outlined below. Be sure to refer to the AC drive instruction manual as these steps are performed. Please direct all installation inquiries that may arise during the installation and start-up of this product to the equipment supplier or system integrator.

3.1. ENVIRONMENT

The module should be installed in an area protected from moisture and falling debris. Buildup of dust or debris may cause poor performance and possibly a failure. Operating in a wet environment can pose a shock hazard. The recommended temperature range for operating this module is 0 to +40°C. Device shall be installed in a pollution degree 2 environment.

3.2. UNPACKING

Upon receipt of this product, please verify that the product received matches the product that was ordered and that there is no obvious physical damage to the unit. If the wrong product was received or the product is damaged in any way, please contact the supplier from which the product was purchased.

3.3. MOUNTING

3.3.1. M3645P DC BUS REGENERATIVE POWER SUPPLY

The installation site for the M3645P power supply should be chosen with several considerations in mind:

- When mounting regen units in an enclosure, power dissipation should be taken into account. Refer to Section 6.3 Watt Loss for details.
- The unit requires a minimum clearance of two (2) inches in all directions around it when not mounted near a heat source. Heat sources may increase necessary clearances.
- Unit should not be exposed to falling debris or condensation.

Once the installation site has been selected as outlined above, the unit should be mounted in place.

The M3645P must be properly oriented for proper heat flow through the unit. The M3645P must be mounted with the rear surface of the unit to the mounting surface. The unit may be mounted vertically (Figure 3-1D), or with its backplane down and parallel to the ground (Figure 3-1A).

Do Not mount the unit on the underside of a mounting surface as shown in Figure 3-1B.

Do Not mount the unit in a horizontal position with its side parallel to the mounting surface or floor as shown in Figure 3-1C.

Do Not mount the unit in an upside-down position, as shown in Figure 3-1E.

Refer to Table 2-3: Chassis Styles to determine the chassis for the unit. Mounting dimensions and provisions vary by unit chassis. See Figure 3-1 for mounting orientation information and Section 6.6 for dimensional drawings.

Figure 3-1: M3645P Mounting Orientation

Figure 3-1A

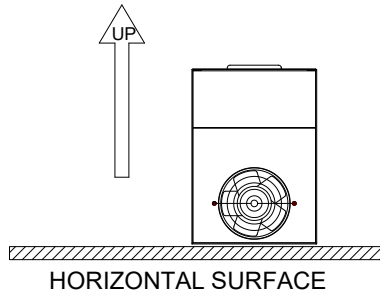

Figure 3-1D

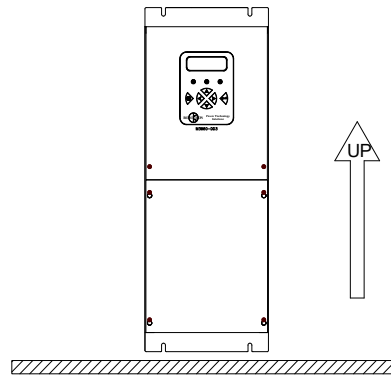

Figure 3-1B

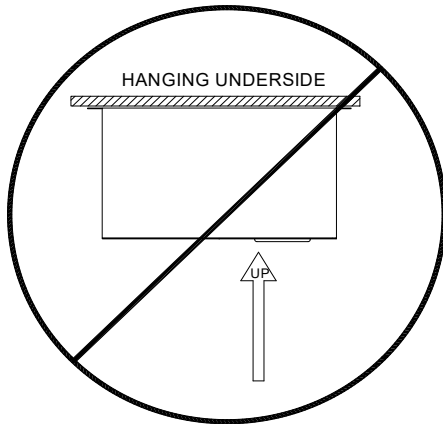

Figure 3-1E

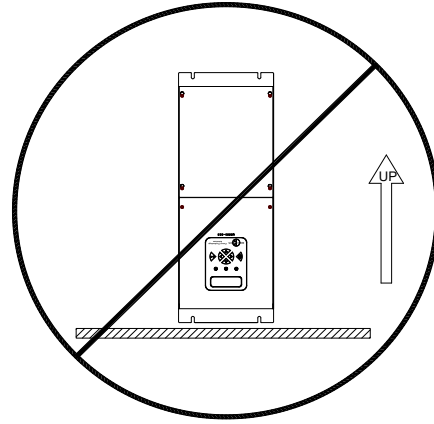
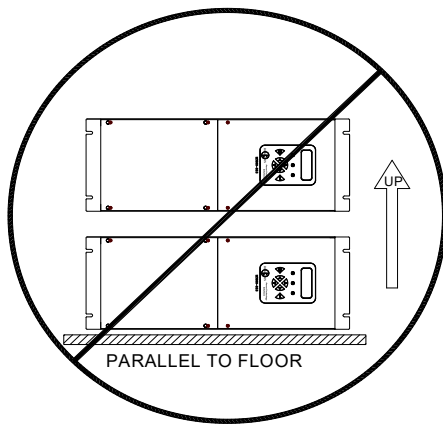

Figure 3-1C



3.3.2. M3645 M15 LINE REACTOR MOUNTING

The installation of the M3645 M15 line reactor should be chosen with several considerations in mind:

- The M3645 M15 line reactor is only required when using the 150A, 225A, and 300A rated M3645 in the M15 chassis.
- When mounting the line reactor in an enclosure, power dissipation should be taken into account. Refer to Section 6.3 Watt Loss for details.
- The unit requires a minimum clearance of two inches (2") in all directions around it when not mounted near a heat source. Heat sources may increase necessary clearances.
- Unit should not be exposed to falling debris or condensation.
- The unit can be mounted in any orientation.

Once the installation site has been selected as outlined above, the unit should be mounted in place. See Section 6.6 for dimensional drawings.

3.3.3. KIT 3645DD, EXTERNAL DISPLAY MOUNTING

The KIT 3645DD external display is comprised of the display board assembly (ASM 3645D3) and a 12-foot-long cable (CBL 3660DD4-DI12). The installation should be chosen with several considerations in mind:

- The external display requires a cutout from the front panel. See Figure 6-6 for the dimensional requirements for the cutout.
- The display will attach to the front of the panel. The display is secured to the panel with a screw in each corner.
- The unit requires a minimum clearance of one (1) inch in all directions around it.
- The unit should not be exposed to falling debris or condensation.
- The 12-foot cable provided with the display must be attached to TB6 on the control board of the M3645P and to TB2 on the ASM 3645D4 on the rear of the display. See Figure 3-13 and 3-14.

Once the installation site has been selected as outlined above, the unit should be mounted in place. See Section 6.6 for dimensional drawings.

NOTE: The KIT 3645DD is only compatible with "L" versions of the M3645P power supply. Only a single display can be used for each line regen. The line regen is unable to power more than a single display.

3.4. WIRING AND CUSTOMER CONNECTIONS

Be sure to review all pertinent AC drive and system documentation as well as the information listed below before proceeding. Connection points and terminal numbers of the AC drive will be found in the documentation provided with those units. See Tables 3-1 thru 3-6 and Figures 3-2 thru 3-8 for connection details.

3.4.1. POWER WIRING



Only qualified electricians should perform and maintain the interconnection wiring of this product. All wiring should be in accordance with local codes.



Do NOT daisy chain the AC, DC, or ground connections between multiple power supply units. Each power supply should have separate power and ground connections.

- Where possible, minimize the wire length between the Power Supply and the Drive. The wire length should not exceed 10 feet.
- Avoid routing and bundling the Power Supply AC/DC wiring with the Drive AC PWM motor output wiring.

3.4.1.1. 3-PHASE AC INPUT

Do not install chokes or reactors between the power supply and the power source. M3645P has an internal 5% line reactor.

If an isolation transformer is to be used, the transformer should meet the ratings shown in Table 3-1.

Table 3-1: Transformer Ratings

Model	Minimum kVA	Maximum Impedance
L30	13.5 kVA	5.0%
E30	23 kVA	2.9%
H30	26.5 kVA	2.5%
C30	33 kVA	2.0%
L50	22 kVA	6.0%
E50	38 kVA	3.4%
H50	44 kVA	3.0%
C50	55 kVA	2.4%
L100	44 kVA	6.3%
E100	75.5 kVA	3.6%
H100	87.5 kVA	3.1%
C100	109.5 kVA	2.5%
L150	75 kVA	5.0%
E150	125 kVA	6.0%
H150	150 kVA	4.0%
L225	100 kVA	5.0%
E225	170 kVA	6.0 %
H225	200 kVA	4.0%
L300	131 kVA	4.4%
E300	226.5 kVA	2.5%
H300	262 kVA	2.2%

Do not connect to a generator. For further details, contact Bonitron. The AC line connections should have short-circuit current protection. Recommended fuses are listed in Section 6.5.

3.4.1.2. INTER-MODULE WIRING FOR 150A, 225A, AND 300A UNITS

For M3645 rated for 150A, 225A, and 300A an individual line reactor must be used in front of each line regen module. See Figure 3-10 for wiring diagram.

The user must wire both the control AC wiring from the line reactor to the line regen module. The control wiring must be connected to the utility side of the line reactor and is phase sensitive.



The AC control wiring to the 150 A, 225 A, and 300 A units is phase sensitive. If the AC control wiring is not in phase with power wiring catastrophic damage to equipment will result.

3.4.1.3. DC BUS INPUT

The DC bus input may be connected to the DC bus of a single AC drive or to a common DC bus. If a reactor or choke are being used in the bus, make sure the actual connection is in parallel with filter capacitors of the drive/inverter.



Never attach the DC bus input of the M3645P to braking terminals on the AC drive, commonly marked “BR”. These terminals are intended for use with an external resistor, and are not directly connected to the bus filter capacitors of the drive. Damage may occur if these terminals are used. Please refer to your AC drive manual or AC drive technical support department for assistance with this connection.

3.4.1.4. GROUNDING

Using the ground stud provided, ground the chassis in accordance with local codes. Typically, the wire gauge will be the same as is used to ground the attached drive.

Table 3-2: Power Terminal Specifications - 30 Amp Unit – M10 Chassis

TERMINALS	FUNCTION	ELECTRICAL RATINGS	WIRE SIZE MINIMUM	WIRE SIZE MAXIMUM	TORQUE
L1, L2, L3	AC line outputs	30 A	8 AWG	2 AWG	32 lb-in
DC+, DC-	DC bus inputs	30 A	8 AWG	2 AWG	32 lb-in
GND	Ground		10 AWG	1/0	50 lb-in

Table 3-3: Power Terminal Specifications - 50 Amp Unit – M11 Chassis

TERMINALS	FUNCTION	ELECTRICAL RATINGS	WIRE SIZE MINIMUM	WIRE SIZE MAXIMUM	TORQUE
L1, L2, L3	AC line outputs	50 A	4 AWG	2/0	120 lb-in
DC+, DC-	DC bus inputs	50 A	4 AWG	2/0	120 lb-in
GND	Ground		8 AWG	1/0	50 lb-in

Table 3-4: Power Terminal Specifications - 100 Amp Unit – M12 Chassis

TERMINALS	FUNCTION	ELECTRICAL RATINGS	WIRE SIZE MINIMUM	WIRE SIZE MAXIMUM	TORQUE
L1, L2, L3	AC line outputs	100 A	1 AWG	2/0	120 lb-in
DC+, DC-	DC bus inputs	100 A	1 AWG	2/0	120 lb-in
GND	Ground		6 AWG	1/0	50 lb-in

Notes: All power wire should be selected to match or exceed the voltage rating of the unit. Field wiring for terminals will be copper 75°C wire only.

Figure 3-2: Power Connections

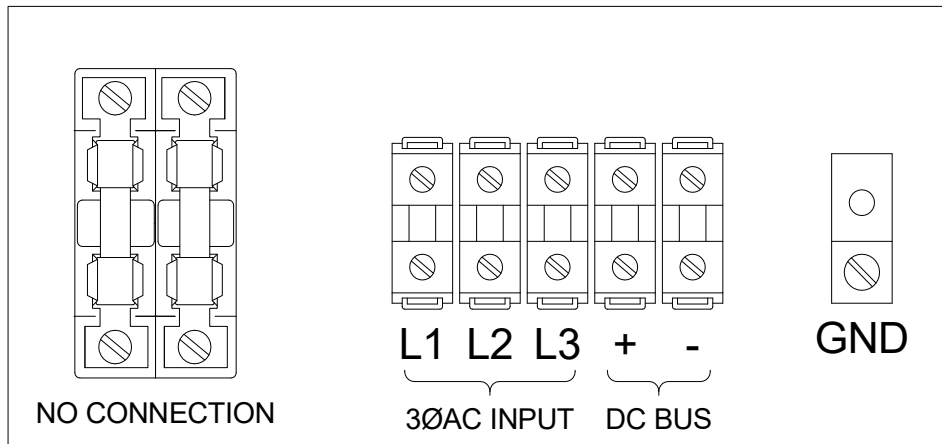
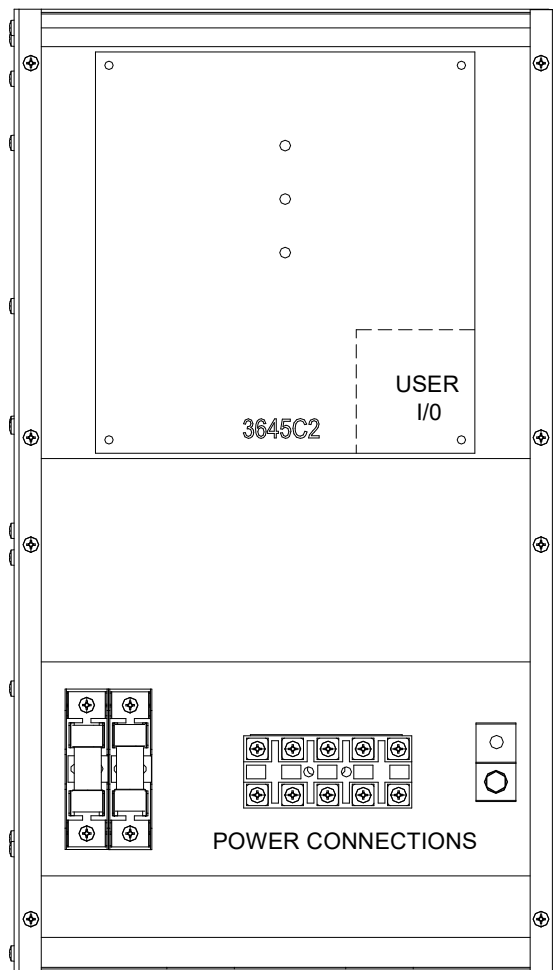

Figure 3-3: Connection Locations





The AC control wiring to the 150A, 225A, 300A units is phase sensitive. If the AC control wiring is not in phase with power wiring catastrophic damage to equipment will result.

Table 3-5: Power Terminal Specifications – 150A, 225A, and 300A Unit – M15 Chassis

TERMINALS	FUNCTION	ELECTRICAL RATINGS	WIRE SIZE MINIMUM	WIRE SIZE MAXIMUM	TORQUE
L1, L2, L3	AC control power		18 AWG	10 AWG	4.4 lb-in
A2, B2, C2	AC line outputs	300 A	3/0	350 kcmil	275 lb-in
DC+, DC-	DC bus inputs	300 A	3/0	350 kcmil	275 lb-in
GND	Ground		3 AWG	1/0	50 lb-in

Notes:

L1, L2, L3 AC control power and A2, B2, C2 AC line output are phase sensitive, switching the order of phases to any of the inputs may result in damage to the regen.

All power wire should be selected to match or exceed the voltage rating of the unit.

Field wiring for terminals will be copper 75°C wire only.

Figure 3-4: M3645P 150A, 225A, and 300A Power Connections

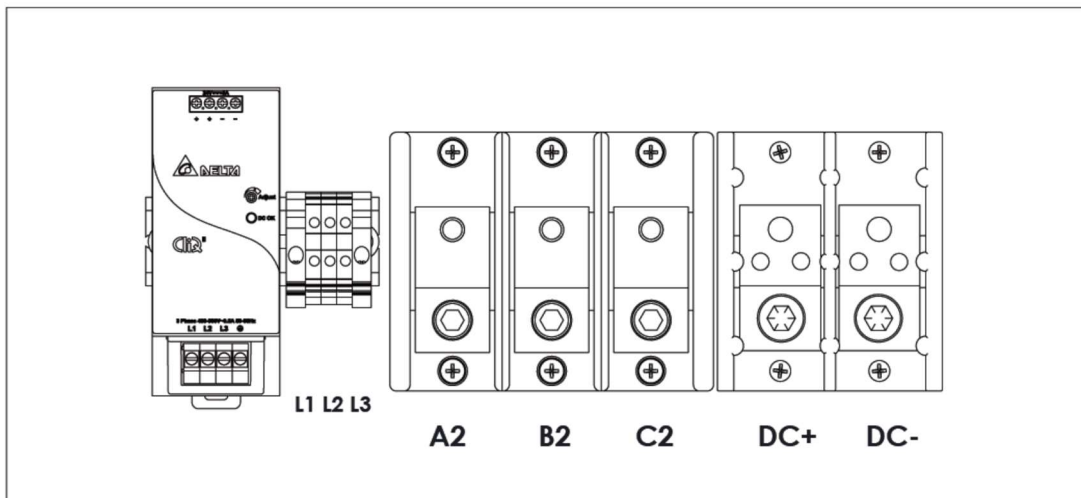

Figure 3-5: M3645P 150A, 225A, and 300A Connection Locations

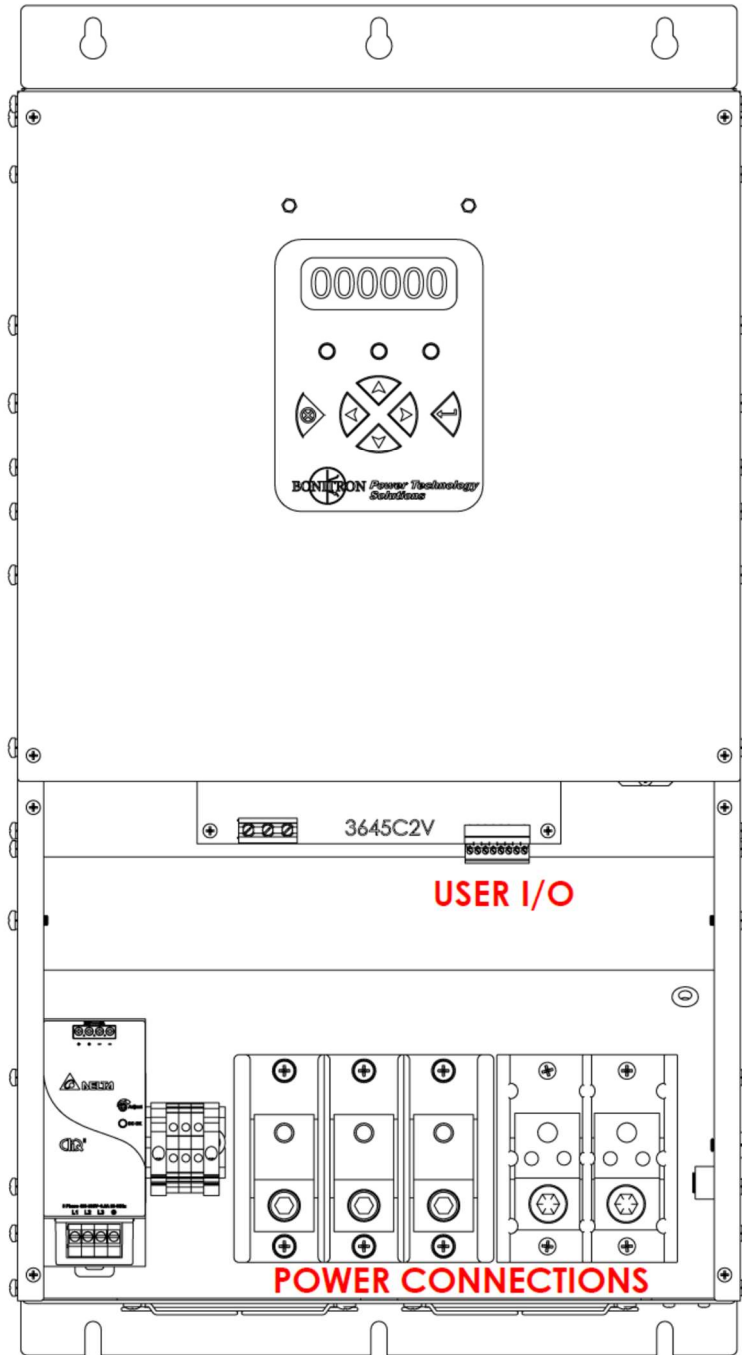
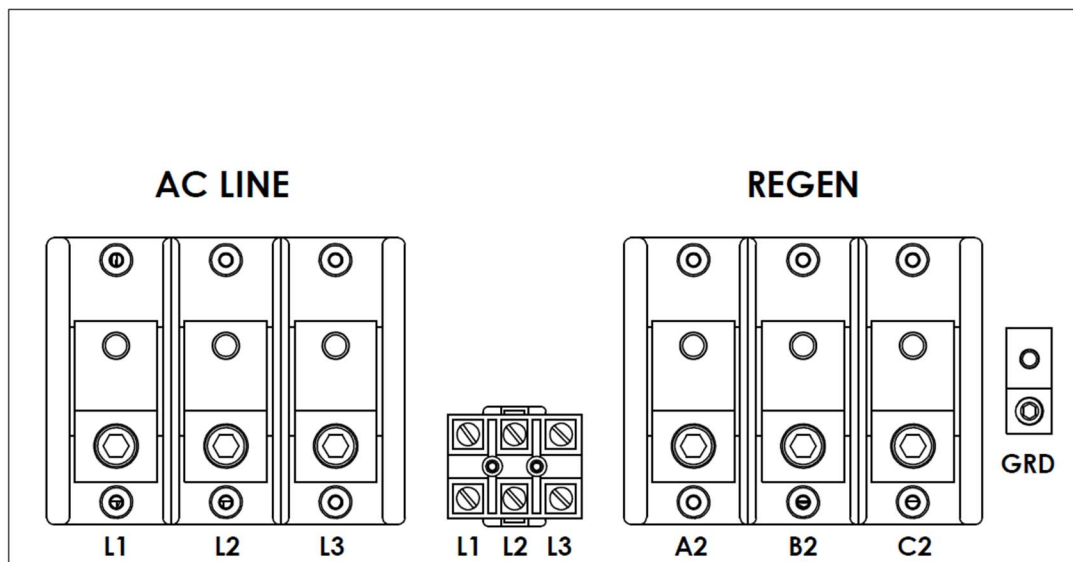

Table 3-6: Power Terminal Specifications – 150A, 225A, and 300A Unit – Line Reactor

TERMINALS	FUNCTION	ELECTRICAL RATINGS	WIRE SIZE MINIMUM	WIRE SIZE MAXIMUM	TORQUE
POWER L1, L2, L3	AC line output to Mains	300A	3/0	350 kcmil	275 lb-in
CONTROL L1, L2, L3	AC control power to regen		18 AWG	10 AWG	4.4 lb-in
A2, B2, C2	AC line input from regen	300A	3/0	350 kcmil	275 lb-in
GND	Ground		3 AWG	1/0	50 lb-in

Figure 3-6: M3645 150A, 225A, and 300A Reactor Connections



3.4.2. I/O WIRING

User I/O is connected via TB2 on the internal 3645C2 or 3645C4 circuit board. To access this terminal, the front panels of the unit must be temporarily removed. The inputs can be driven either from an external 24VDC supply, or from the internal 24V supply. **To use the internal 24V supply, TB2-4 and TB2-5 must be shorted.**

Units with serial numbers 2515 and later have a 3645C4 control board. On this board, TB 2-7 has a selectable output. When jumper J6 is in the "OT" position, TB2-7 is an overtemp output. The contactor will open when you unit goes into an overtemp fault. When J6 is in the "RA" position, TB2-7 is an Regen Active indicator. The contactor will close when the regen is active. The unit is shipped with jumper J6 in the "OT" position.

Units with serial number before 2515 have a 3645C2 board. On this board TB2-7 is only an overtemp output. The contactor will open when the unit goes into an overtemp fault.

No additional I/O wiring is required for running multiple M3645 line regens in parallel.

Note: since the Overtemperature Fault cannot shut down the power supply directly, the Overtemperature output should be used to reduce or disable the load in the event of an Overtemperature Fault. Otherwise an overload condition may result in catastrophic failure.

Table 3-7: I/O Terminal Specifications

TERMINAL	FUNCTION	ELECTRICAL SPECIFICATIONS	MIN WIRE AWG	MAX WIRE AWG	TORQUE
TB2-1	+24V	24VDC to TB2-5	18	16	2.2 lb-in
TB2-2	Enable Input	24VDC 5mA	18	16	2.2 lb-in
TB2-3	Fault Recall Input	24VDC 5mA	18	16	2.2 lb-in
TB2-4	Input COM	COM to TB2-2, -3	18	16	2.2 lb-in
TB2-5	24V COM	COM to TB2-1	18	16	2.2 lb-in
TB2-6	Ready Output NO	250V 150 mA	18	16	2.2 lb-in
TB2-7	Overtemp Output NO	250V 150 mA	18	16	2.2 lb-in
TB2-8	Output COM	COM to TB2-6, -7	18	16	2.2 lb-in

Note: Field wiring for terminals will be copper 75°C wire only.

*Selectable via jumper J6 on 3645C4 board, Overtemp only on 3645C2 board

Figure 3-8: M3645P Enable Input Using Internal Power Supply

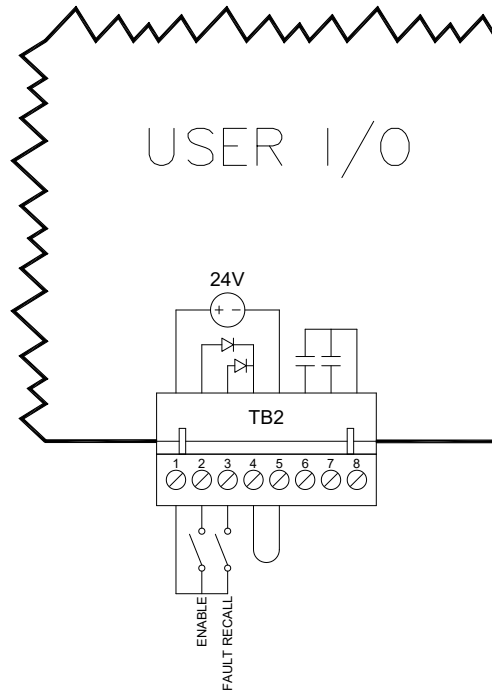

* FACTORY SETTING INCLUDES JUMPERS ACROSS ENABLE.
JUMPER MUST BE PRESENT TO ENABLE REGEN.

Figure 3-9: M3645P Enable Input Using External Power Supply

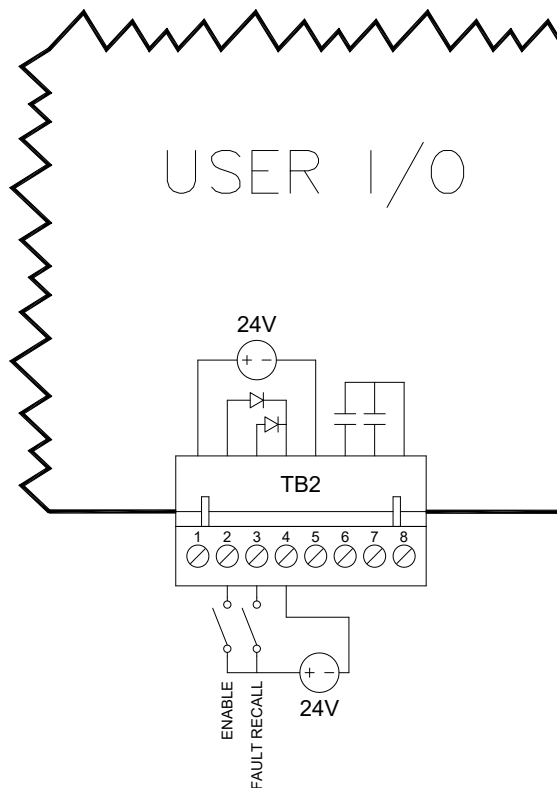

3.5 TYPICAL CONFIGURATIONS

The diagrams shown in Figures 3-10, 3-11, 3-12 illustrate typical connections of a M3645P unit with generic VFDs. There are many other configurations that may be applied, providing basic connection criteria are maintained, including:

- The AC terminals should have a low impedance path back to the grid.
- No reactors should be connected upstream of the unit without consulting Bonitron for instructions.
- The AC feed to the VFDs should be left disconnected.
- The DC terminals should be connected to a fixed bus of one or more VFDs. This should never be connected to a switching source such as the braking resistor terminals on some drives.
- The DC terminals should not be connected to an active front end drive without instructions from Bonitron.

Figure 3-10: M3645P 30A, 50A, 100A Power Wiring

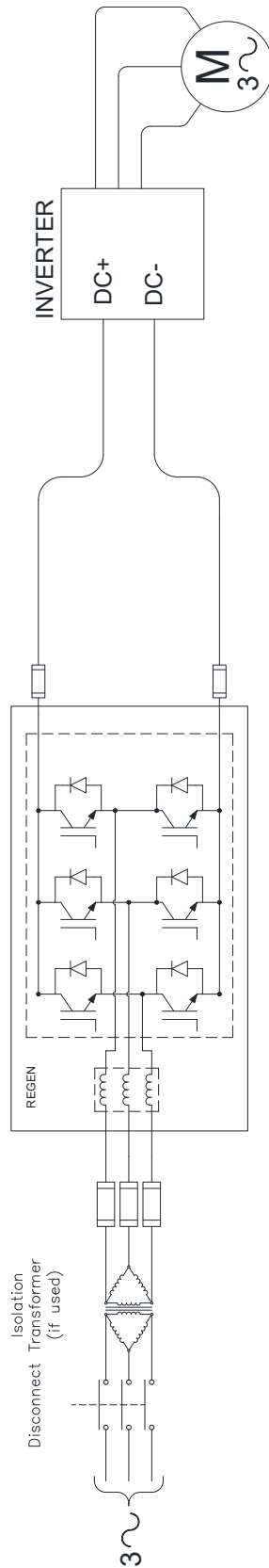

Figure 3-11: M3645P 150A, 225A, and 300A Power Wiring

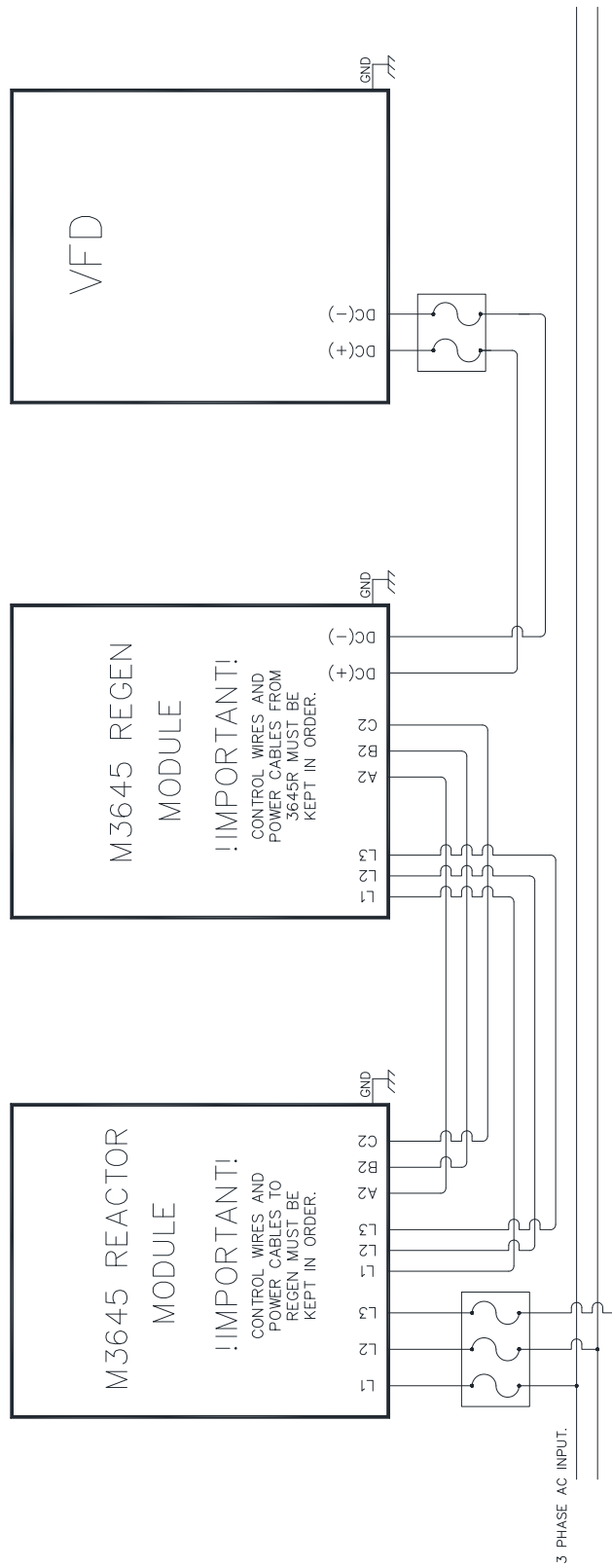

Figure 3-12: M3645P Multiple Drives Field Wiring Diagram

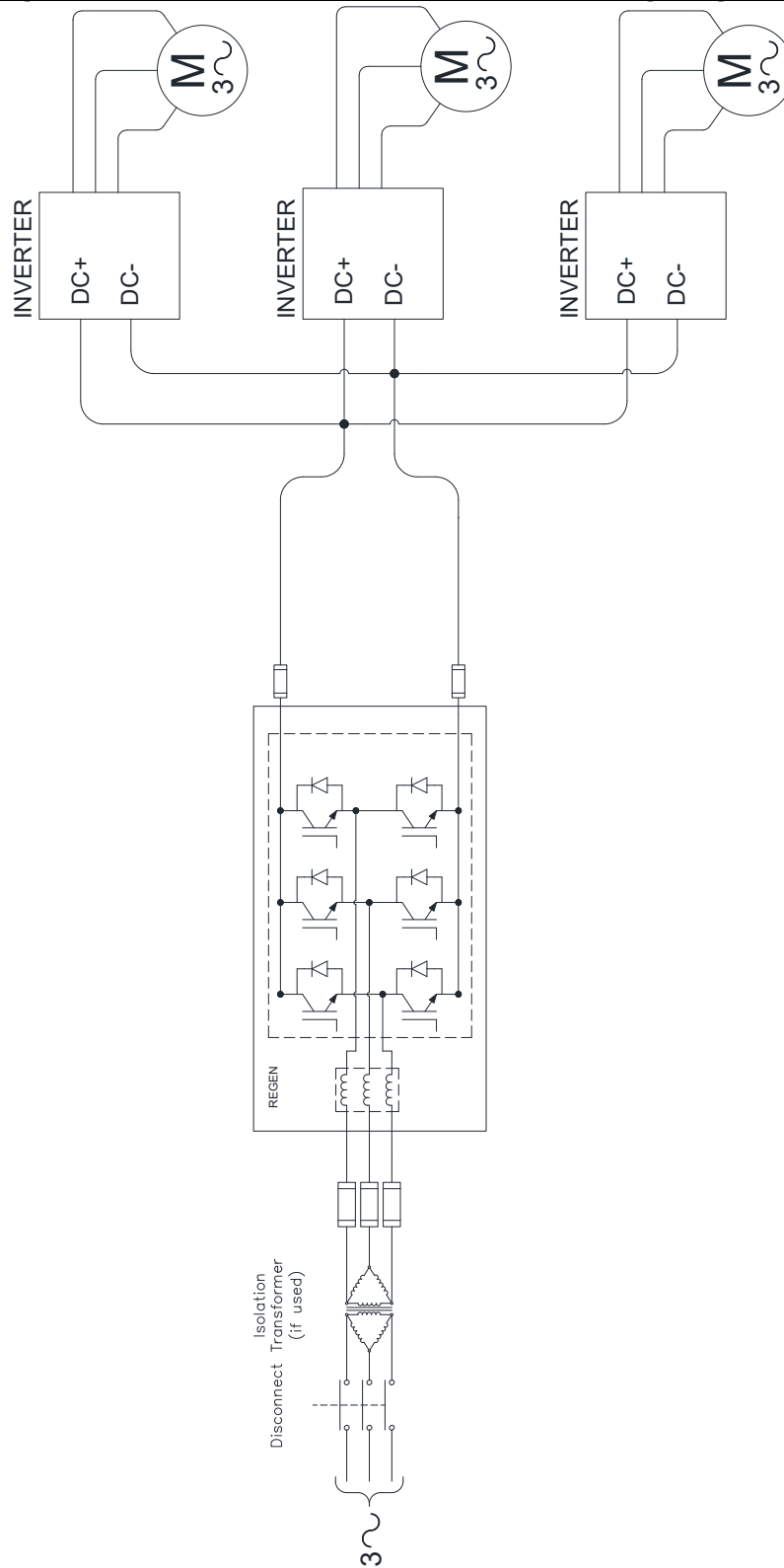

Figure 3-13: M3645P Connection with KIT 3645DD, External Panel Mounted Display

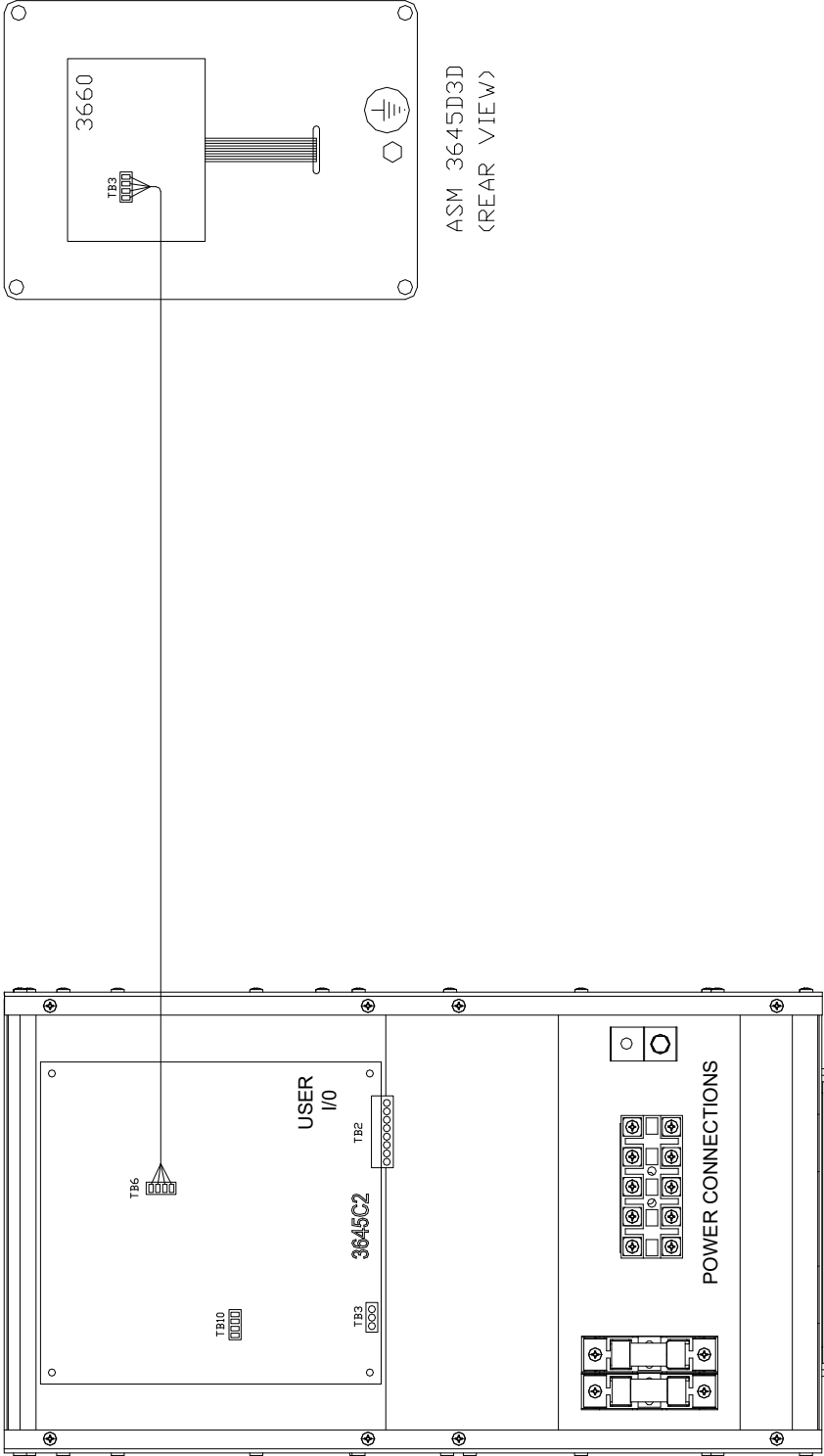
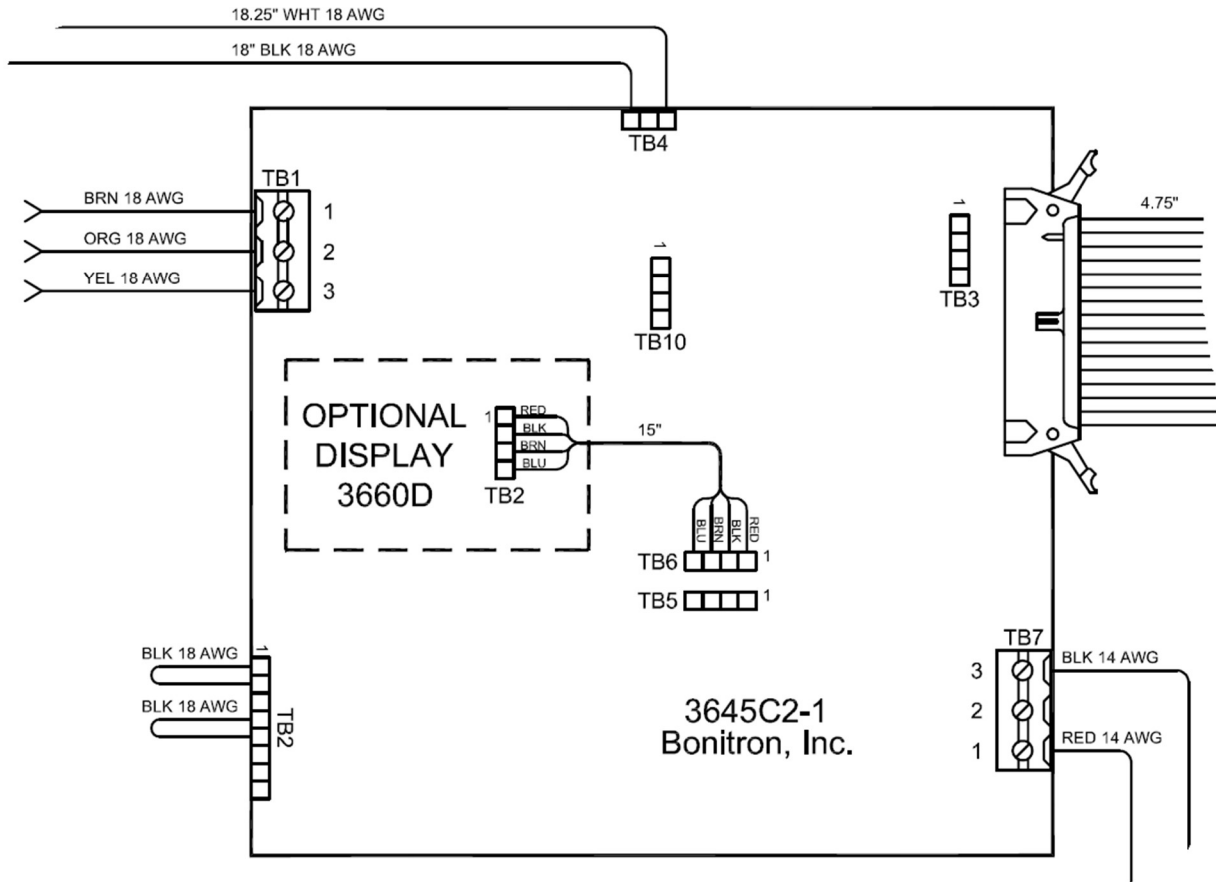

Figure 3-14: M3645P Connection with KIT 3645DD, External Display Wiring



4. OPERATION

4.1. FUNCTIONAL DESCRIPTION

The M3645P regenerative DC bus power supply enables energy being generated by an overhauling motor to be efficiently returned to the power grid. It also supplies power to one or more drives through their DC bus terminals.

M3645P synchronizes to the frequency of the attached power line, automatically adapting to 50Hz or 60Hz. During motoring, the unit acts as a passive six-pulse rectifier with an internal 5% reactor. As the DC bus rises above the AC line peak, the unit drives current from the DC bus into the AC line to limit the rise in bus voltage. During regeneration the unit is self-limiting, and will automatically fold back or shut down in the event that unsafe conditions are detected.

An optional digital display shows information about the power supply's present status and history. Fault records and a lifetime count of energy regenerated are stored. On units without digital displays, system information is presented via three color LEDs.

4.2. FEATURES

4.2.1. DIGITAL DISPLAY

The optional display is a four-line, eighty-character LCD which shows information about the present status of the unit, as well as records of faults and energy throughput.

4.2.2. LEDs

Red, yellow, and green LEDs indicate the status of the unit.

4.2.2.1. POWER (GREEN) INDICATOR

The green LED indicates that the unit is powered on.

4.2.2.2. REGEN ACTIVE (YELLOW) INDICATOR

The yellow LED indicates that the unit is actively regenerating power back to the line.

4.2.2.3. NOT READY (RED) INDICATOR

The red LED indicates that the unit is not ready to regenerate. The red LED will be off during normal operation.

On units with a digital display, the red LED will illuminate if a fault has occurred, or if the unit's enable input (4.5.2) is not activated. In case of a fault, the display will indicate the nature of the fault.

On units without a digital display, the red LED turns on solid if the enable input (4.5.2) is not activated. If any faults are present, the red Not Ready LED will blink out a code indicating the present fault (Table 4-1).

Note that neither condition will prevent the unit from operating as a power supply. Only the regeneration functions are affected by faults or the enable signal.

4.2.3. BUTTONS

Up, down, left, right, cancel, and enter buttons are present on the face of Regen units equipped with a digital display. The function of each button depends on the active screen. See Section 4.3 for details.

4.3. DIGITAL DISPLAY OPERATION

These screens display information about the M3645P on units equipped with digital displays.

4.3.1. METERING SCREEN

This screen displays the present DC bus voltage, DC bus current, power being supplied or regenerated, and how long the unit has been powered on since shipment.

Left: Faults screen

Right: Faults screen

Down: Energy Records screen

4.3.2. ENERGY RECORDS SCREEN

This screen displays the total energy regenerated by the unit since shipment, along with the total energy regenerated since the user reset the energy count.

Up: Metering screen

Down: Reset Energy Records screen

4.3.3. RESET ENERGY RECORDS SCREEN

This screen allows the user to reset the record of energy regenerated by the unit. This screen also displays the firmware version present on the unit.

Up: Energy Records screen

Enter: Confirm reset

4.3.4. FAULTS SCREEN

This screen shows the present fault state of the unit, scrolling through all faults detected, if any.

Left: Metering screen

Right: Metering screen

Down: Fault Records screen

4.3.5. FAULT RECORDS SCREEN

This screen shows a record of a previous fault state, including all faults and the time since first power-on that the fault state occurred. The display stores the 50 most recent fault states.

Left: Previous fault in the record

Right: Next fault in the record

Up: More recent fault state

Down: Older fault state

Cancel: Faults screen

Figure 4-1: M3645P Screen Tree

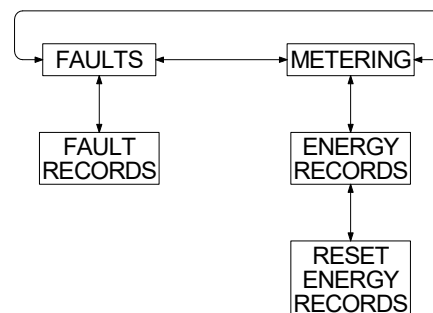

4.4. FAULTS

The M3645P monitors several different fault conditions which prevent regeneration from occurring. Some faults latch until they are reset by toggling the enable input. Faults that do not latch will automatically clear when the fault condition is no longer present. Every fault opens the Ready Output contact (4.5.5).

On units with a digital display, the display stores the last 50 fault records (4.3.5). On units without a digital display only the most recent fault state can be viewed. The unit's most recent fault state may be accessed by disabling the unit (4.5.2), then setting the Fault Recall Input (4.5.3) high. The red Not Ready LED (4.2.2.3) will blink out all the faults of the most recent fault state, in sequence.



Faults will not prevent the power supply from operating. Only the regeneration mode will be disabled during a fault event.

Table 4-1: Blink Codes

FLASHES	FAULT
Solid	Unit is not Enabled
1 Fast	Feedback Undervoltage
2 Fast	Overtemperature
3 Fast	DC Overvoltage
4 Fast	Differential Overvoltage
5 Fast	Sync Loss
1 Slow	IGBT Driver
2 Slow	Phase Overcurrent
3 Slow	Phase Loss
4 Slow	DC Undervoltage
5 Slow	Regen Power-On/Precharge Not Complete
6 Slow	Frequency Detect Failure

Note: Slow: 1 blink per second
Fast: 3 blinks per second

4.4.1. FEEDBACK UNDERVOLTAGE

This fault indicates that the unit's DC bus feedback circuitry has failed. This fault will latch until manually cleared by toggling the Enable Input. If this fault does not clear, it typically indicates that damage to the M3645P has occurred and must be repaired.

4.4.2. OVERTEMPERATURE

This fault indicates that the unit has exceeded its safe operating temperature. This fault will automatically clear when the unit's temperature has returned to a safe level.



Note: Since the Overtemperature Fault cannot shut down the power supply directly, the overtemp output should be used to disable the drive in the event on an overtemp. Otherwise an overload condition may result in catastrophic failure.

4.4.3. DC OVERVOLTAGE

This fault indicates that the DC voltage on the bus has exceeded 1000V. This fault latches until manually cleared.

4.4.4. DIFFERENTIAL OVERVOLTAGE

This fault indicates that the DC bus is more than 200V higher than the AC line peak. This fault latches until manually cleared by toggling the Enable Input.

4.4.5. SYNC LOSS

This fault indicates that the regen has lost synchronization with the AC line. This fault will automatically clear if sync is reestablished, and will latch if it cannot. If this fault recurs regularly or fails to clear, it is likely due to line noise, a blown phase fuse, or an undersized AC source.

4.4.6. IGBT DRIVER

This fault indicates that the unit's internal transistor drive circuitry has detected an error. This typically indicates an instantaneous overcurrent on one of the AC legs. This fault will latch until cleared by toggling the Enable Input. If this fault does not clear, it typically indicates that damage to the unit has occurred.

4.4.7. PHASE 1-3 OVERCURRENT

These faults indicate that the current the unit is regenerating into one leg of the AC line has exceeded a safe operating level. This is likely due to voltage distortion on the line. These faults will latch until cleared by toggling the Enable Input.

4.4.8. PHASE LOSS

These faults indicate that the unit has lost voltage on one or more of the AC line phases. These faults clear automatically when voltage is reestablished. If these faults do not clear, it typically indicates that a line fuse has failed.

4.4.9. DC UNDERVOLTAGE

This fault indicates that the DC voltage on the bus is less than 100V. This fault will clear automatically when the voltage rises to an operable level. If this fault does not clear, it typically indicates that damage to the unit has occurred.

4.4.10. REGEN POWER-ON/PRECHARGE NOT COMPLETE

These faults indicate that the unit has been powered on in the last ten seconds. This fault will clear automatically. If this fault does not clear, it typically indicates that damage to the unit has occurred.

4.4.11. FREQUENCY DETECT FAILURE

This fault indicates that the unit failed to properly detect whether the AC source is 50 or 60 Hz. This fault latches until power-down.

4.5. INPUT / OUTPUT CONNECTIONS

All the inputs for the unit are rated for 24VDC. All inputs are common to TB2-4. The inputs are bidirectional, and can be configured to be sinking or sourcing as the installation requires. It is recommended that inputs be configured as sinking, as this is more failsafe.

The outputs are MOSFET optocouplers common to TB2-8, and will show a low resistance (20 Ω) to this common when activated. When not activated, they will appear open.

4.5.1. LOCAL I/O +24V SUPPLY- TB2-1 & TB2-5

This pin supplies 24V, a maximum of 100mA, which can be used to drive the user inputs. +24V is on TB2-1 and 24V Common is on TB2-5.

4.5.2. ENABLE INPUT - TB2-2

This input enables the unit to regenerate. Faults are reset on a rising edge of this input. Note that the unit will not regenerate unless this input is active. The unit will operate in power supply mode regardless of the state of this input.

4.5.3. FAULT RECALL INPUT -TB2-3

For units with no digital display, the last fault record can be retrieved by disabling the unit and activating this input.

The last fault code will blink out until the unit is re-enabled.

For units with a digital display, this input has no function.

4.5.4. INPUT COM -TB2-4

All user inputs are common to this terminal.

4.5.5. READY OUTPUT - TB2-6

This output closes to TB2-8 when the unit is ready to operate. This contact will open if the system is not enabled, if the system is powered off, or on any fault condition.

4.5.6. OVERTEMPERATURE OUTPUT/REGEN ACTIVE - TB2-7

When J6 is in the "OT" position this output closes to TB2-8 when the unit is not indicating an overtemp fault and opens if the unit reaches an unsafe operating temperature. This contact should be monitored, and the load on the power supply should be reduced or removed in the event of an overtemp fault. Otherwise damage to the power supply may result. When J6 is in the "RA" position this output closes to TB2-8 when the regen is actively regenerating. (On the 3645C2 boards the output only functions as an overtemp output)



*The M3645P will continue to rectify incoming voltage and operate with the temperature switch open.
Continued operation with the temperature switch open can cause dangerous overheating of the M3645P, and can cause permanent damage, and catastrophic failure.*

4.5.7. OUTPUT COM - TB2-8

This terminal is the common to the outputs. It is not common to TB2-4, and allows the use of a different power supply for outputs if the installation requires.

4.6. STARTUP

This section covers basic checks and procedures that should be used when performing a startup with a M3645P regenerative DC bus power supply.

4.6.1. PRE-POWER CHECKS

- Ensure that the voltage of the AC power system is the same as the voltage rating of the unit.
- Ensure that all connections are tight and that all wiring is of the proper size and rating for operation.
- Verify continuity of all input fuses prior to applying power.
- Check for exposed conductors that may lead to inadvertent contact.
- Check for any debris, shavings, trimmings, etc. that may cause shorts or obstruct ventilation on unit.

4.6.2. STARTUP PROCEDURE AND CHECKS

After completing pre-checks and recommended checks for connected equipment, you may apply power to the system. The Power indicator on the front panel should illuminate. The fan should start, then stop within ten seconds. Attached drive units should also power on.

Enable the unit by placing 24VDC on the "Enable" input. (Table 3-6 or Table 3-7 for 150A, 225A, and 300A units)

The Status Contact should be closed after a 2 second delay, which is an indication that unit is ready for operation.

Observe the current on the digital display, or with a current clamp for systems without a digital display. If more than 5 amps are flowing with the attached drive not operating, go to the Troubleshooting instructions in Section 5.3.

Once the Status output closes, the unit is ready to operate in regen mode, and the drive system can be run normally.

4.6.3. COOLING FAN

The cooling fan will not run all the time. The fan runs at startup, when the unit is regenerating, or when the unit's internal temperature is above a certain level. If the cooling fan never runs, there may be damage to the fan and the unit may need repair.

5. MAINTENANCE AND TROUBLESHOOTING

Repairs or modifications to this equipment are to be performed by Bonitron approved personnel only. Any repair or modification to this equipment by personnel not approved by Bonitron will void any warranty remaining on this unit.

5.1. PERIODIC TESTING

There are no requirements for periodic testing of these units. It may be beneficial to repeat start-up procedures and checks when performing routine maintenance.

5.2. MAINTENANCE ITEMS

Check the fan periodically for debris, and blow out with an air hose if it has become obstructed or not running at full capacity. **Power should not be applied when blowing dust and debris out of unit.**

5.3. TROUBLESHOOTING



There are no user serviceable parts within the M3645P. If you are still experiencing problems after you have reviewed this whole section, you may contact Bonitron for additional assistance at (615) 244-2825.

5.3.1. POWER LED IS NOT ON, OR DIGITAL DISPLAY IS NOT ACTIVE:

- Check AC input voltage at terminals. Voltage should be within range specified in Table 2-1 for your unit. If the power light will not come on, check any overcurrent devices or disconnects upstream of the unit.
- If the power lamp will not come on, it is likely that the unit is damaged and needs to be repaired.

5.3.2. READY OUTPUT WILL NOT CLOSE

The Ready output indicates that the module is enabled and in a ready condition. When the power is applied to the module, the Ready output will normally close after a startup delay of approximately 2 seconds. Thereafter, the Ready output should be closed, indicating that the system is ready to operate. If the Ready output fails to close, one of several faults may be indicated.

- Make sure the Power LED is on.
If the Fault LED is blinking, refer to Table 4-1, "Blink Codes" to determine which fault is active, or look at the digital display.
- If the Fault LED is on solid, the "Enable" input is not activated.

5.3.3. UNIT WILL NOT RESPOND TO ENABLE COMMAND

- Confirm that 24V is present between TB2-2 and TB2-4 (see Figure 3-6).
- If the internal 24V supply is being used, confirm that a jumper is present between TB2-4 and TB2-5.

5.3.4. DRIVE TRIPS ON DC BUS OVERVOLTAGE DURING BRAKING

If an attached drive trips on overvoltage, it typically indicates the M3645P is not regenerating. There are some simple things that can determine the cause.

- Make sure the unit has power and is enabled. The "Ready" output will close if the unit is ready to operate. (4.5.2)

- See if there are any faults reported.
- Check DC bus voltage at fuses.
- Check DC bus polarity at fuses.
- Check DC bus fuses for continuity.
- Ensure unit is not faulting during operation. Some faults may clear themselves, such as phase loss, but fault recall will show that they have occurred. Check the fault records to see if the unit has recorded faults that would cause the operation to stop regenerating, resulting in a drive overvoltage.
- Confirm that the unit is properly sized. If the braking energy is too high for the unit to regenerate, the unit will go into current limit, which will result in an uncontrolled bus voltage rise. The current being regenerated can be checked with the digital display or with a separate meter in the DC link. If the unit is operating in current limit, it may be undersized for the application.
- If the M3645P is connected to the AC line through a transformer, the transformer may not be large enough to handle the regenerated currents. See section 3.4.1.1 for transformer sizing instructions.
- With 150A, 225A, and 300A units, confirm that the phase rotation of the AC control power connections between the reactor and the transistor module match the power connections.

5.3.5. **FEEDBACK UNDERVOLTAGE**

Reset the M3645P by toggling the enable input. (4.5.2)
If the fault returns, contact Bonitron for assistance.

5.3.6. **OVERTEMPERATURE**

Check the ambient temperature. If the temperature is above 40°C, the unit may not be able to cool properly at full load. Ensure that there is adequate clearance and airflow in the area where the Regen is installed.

Check to make sure the fan is operating. The fan will operate for a few seconds after power up. Cycle power to the unit and listen for the fan operation. If it does not operate, check for obstruction.

If the unit is cool and still showing an overtemperature condition, contact Bonitron for assistance.

If an overtemperature fault is listed in the fault log in conjunction with a Precharge Not Complete fault, this indicates that control power to the unit has been reset. No actual overtemperature condition has occurred.

5.3.7. **DC OVERVOLTAGE**

If the M3645P indicates a DC bus overvoltage fault, this typically indicates incorrect installation or damage to the unit. The M3645P only indicates this fault if the DC bus registers as over 1000 VDC. For units of L-, E-, or H-voltage classes this is not generally possible. For units of the C- voltage class, check all the conditions described in Section 5.3.34.

Confirm that the system topology matches the diagrams shown in section 3 of the manual.

Confirm with a voltmeter that the DC bus polarity matches the markings on the unit.

This fault may occur if the regen is connected to multiple drives, with blocking diodes between each drive and the regen. This topology is not supported.

Please contact Bonitron for possible alternative common bus solutions.

5.3.8. DIFFERENTIAL OVERVOLTAGE

Differential overvoltage can be caused by the same reasons as the DC Overvoltage. Refer to Section 5.3.7.

5.3.9. SYNC LOSS

Ensure that the overcurrent devices on the incoming AC line are intact.

Ensure that the AC source is properly sized for the application. "Soft" or high impedance sources can have significant voltage distortion that can cause the unit to lose sync. You can check for voltage distortion on the incoming AC line with an oscilloscope and probes of an appropriate voltage class. It will be important to be watching the AC line when the Sync Loss fault occurs, as the distortion may not be present all the time, especially when the line is not loaded.

If a sync loss fault is listed in the fault log in conjunction with a Precharge not Complete fault, this indicates that control power to the unit has been reset. No actual sync loss condition has occurred.

5.3.10. IGBT DRIVER

This fault can be reset by toggling the enable input. (4.5.2)

If the fault cannot be cleared, or occurs frequently, the unit may be damaged. Contact Bonitron for assistance.

If two M3645P units are operated in parallel, IGBT faults may indicate that the parallel combination is undersized for the application.

5.3.11. PHASE OVERCURRENT

This fault can be cleared by toggling the enable input. (4.5.2)

If it occurs frequently, there may be a voltage imbalance on the incoming AC line. Ensure that the incoming line voltages are within 3% of each other.

5.3.12. PHASE LOSS

This fault typically means that the incoming power overcurrent devices or fuses are blown.

Power the unit down and check all fuses and that AC voltage is present at the terminals of the Regen.

5.3.13. DC UNDERVOLTAGE

This may indicate that overcurrent devices in the DC link may have opened. Check the AC and DC voltages with an external voltmeter and make sure they are within specification.

If the voltages are correct, and the fault will not clear, contact Bonitron for assistance.

5.3.14. REGEN POWER-ON/PRECHARGE NOT COMPLETE

This fault is expected to occur every time the unit powers on. It should clear automatically within ten seconds.

If the fault does not clear automatically, power the M3645P down and check all incoming AC and DC fuses or overcurrent devices.

Ensure that DC bus voltage is present at the terminals of the regen, at the expected voltage.

If the fault cannot be cleared, or occurs frequently, the unit may be damaged.

Contact Bonitron for assistance.

5.3.15. FREQUENCY DETECT FAILURE

Power the M3645P down and check all incoming AC and DC fuses or overcurrent devices.

5.3.16. TECHNICAL HELP – BEFORE YOU CONTACT US

If technical help is required, please have the following information available when contacting Bonitron (615) 244-2825, or email to info@bonitron.com):

- Model number of unit
- Serial number of unit
- Name of original equipment supplier if available
- Record the Line to Line voltage on all 3 phases
- Record the DC bus voltage immediately after the AC voltage
- Brief description of the application
- Drive and motor HP or kW
- KVA rating of power source
- Source configuration Wye/Delta and grounding

6. ENGINEERING DATA

6.1. RATINGS CHARTS

Table 6-1: Ratings and Specifications – 230 - 240VAC

MODEL NUMBERS	CHASSIS STYLE	DC REGEN CURRENT		POWER		MAX CONT. WATT LOSS
		CONT.	PEAK	CONT.	PEAK	
M3645P-L030	M10	30 A	45 A	14.4 HP	21.6 HP	180 W
M3645P-L050	M11	50 A	75 A	24.0 HP	36.0 HP	265 W
M3645P-L100	M12	100 A	150 A	48.0 HP	72.0 HP	470 W
M3645P-L150T	M15	150 A	225 A	72.0 HP	108.0 HP	1000 W
M3645-L150R	M15					350 W
M3645P-L225T	M15	225 A	335 A	108.0 HP	160.8 HP	1500 W
M3645-L225R	M15					425 W
M3645P-L300T	M15	300 A	375 A	96.0 HP	120.0 HP	2000 W
M3645-L300R	M15					550 W

Table 6-2: Ratings and Specifications – 380 - 415VAC

MODEL NUMBERS	CHASSIS STYLE	DC REGEN CURRENT		POWER		MAX CONT. WATT LOSS
		CONT.	PEAK	CONT.	PEAK	
M3645P-E030	M10	30 A	45 A	25.0 HP	37.5 HP	180 W
M3645P-E050	M11	50 A	75 A	41.7 HP	62.6 HP	265 W
M3645P-E100	M12	100 A	150 A	83.4 HP	125.2 HP	470 W
M3645P-E150T	M15	150 A	225 A	125.0 HP	187.5 HP	1000 W
M3645-E150R	M15					350 W
M3645P-E225T	M15	225 A	335 A	187.5 HP	279.2 HP	1500 W
M3645-E225R	M15					425 W
M3645P-E300T	M15	300 A	375 A	250.0 HP	312.5 HP	2000 W
M3645-E300R	M15					550 W

Table 6-3: Ratings and Specifications – 460 - 480VAC

MODEL NUMBERS	CHASSIS STYLE	DC REGEN CURRENT		POWER		MAX CONT. WATT LOSS
		CONT.	PEAK	CONT.	PEAK	
M3645P-H030	M10	30 A	45 A	28.8 HP	43.2 HP	180 W
M3645P-H050	M11	50 A	75 A	48.0 HP	72.0 HP	265 W
M3645P-H100	M12	100 A	150 A	96.0 HP	144.0 HP	470 W
M3645P-H150T	M15	150 A	225 A	144.0 HP	216.0 HP	1000 W
M3645-H150R	M15					350 W
M3645P-H225T	M15	225 A	335 A	216.0 HP	321.6 HP	1500 W
M3645-H225R	M15					425 W
M3645P-H300T	M15	300 A	375 A	288.0 HP	360.0 HP	2000 W
M3645-H300R	M15					550 W

Table 6-4: Ratings and Specifications – 575 - 600VAC

MODEL NUMBERS	CHASSIS STYLE	DC REGEN CURRENT		POWER		MAX CONT. WATT LOSS
		CONT.	PEAK.	CONT.	PEAK	
M3645P-C030	M10	30 A	45 A	36.0 HP	54.0 HP	180 W
M3645P-C050	M11	50 A	75 A	60.0 HP	90.0 HP	265 W
M3645P-C100	M12	100 A	150 A	120.0 HP	180.0 HP	470 W

A NOTE ON HP RATINGS

Modules are able to source or regenerate continuous power indefinitely. Modules can source or regenerate peak power for at least 60 seconds.

Each unit’s current and power specifications must be derated by 2% per degree Celsius ambient above 40°C.

6.2. DERATING PARALLEL UNITS

Operating regens in parallel is useful when large regenerative energies are present and need to be dissipated in high power applications. The combined units must have their peak currents derated by 10% each. The derating for parallel systems is shown in Table 6-5.

For applications that may require more than two units in parallel, please contact Bonitron for further assistance. Units with different current ratings should not be in parallel together on the same DC bus.

Table 6-5: Derating Regens in Parallel

INDIVIDUAL M3645P CURRENT RATING	NUMBER IN PARALLEL	DC REGEN CURRENT FOR TWO M3645P IN PARALLEL	
		CONT.	PEAK.
100 A	2	200 A	270 A
300 A	2	600 A	675 A

6.3. WATT LOSS

Tables 6-1 thru 6-4 list the maximum continuous watt loss generated. When installing units in an additional enclosure, consideration should be given to internal temperature rise. The watt loss rating in these tables is based upon the maximum continuous regen capability of each unit. Applications that do not utilize the full capacity may be calculated by using the percentage of loading for the individual unit.

The M3645P is >98% efficient when fully loaded.

6.4. CERTIFICATIONS AND ROHS

M3645P models with 30A, 50A, and 100A ratings are listed under UL508C, file number E204386.

The M3645P line regen is suitable for use on a circuit capable of delivering not more than 65 kA RMS symmetrical amperes at the rated voltage, when protected by the recommended AC fuses. DC fusing is not required.

All M3645P models are in compliance with Directive 2011/65/EU of the European Parliament and of the Council of 8 June 2011 on the restrictions of the use of certain hazardous substances in electrical and electronics equipment (RoHS Directives).

6.5. FUSE SELECTION

Blown fuses typically indicate a semiconductor device failure or a severe transient. In any case, blown fuses should not be replaced without first consulting Bonitron as catastrophic damage can occur.

Use Tables 6-6 and 6-7 when initially constructing the system.

Note: AC fuses must be J-type or equivalent.

Table 6-6: Fuse Current Rating Requirements

MODEL NUMBER	AC / DC FUSE CURRENT RATING
M3645P-x030	40 A
M3645P-x050	60 A
M3645P-x100	125 A
M3645P-x150T	175 A
M3645P-x225T	250 A
M3645P-x300T	350 A

Table 6-7: Fuse Voltage Rating Requirements

SYSTEM VOLTAGE	AC FUSE VOLTAGE RATING	DC FUSE VOLTAGE RATING
230–240 VAC	240 VAC	350 VDC
380–480 VAC	600 VAC	700 VDC
575–600 VAC	600 VAC	1000 VDC

6.6. DIMENSIONS AND MECHANICAL DRAWINGS

Figure 6-1: M3645P M10 Chassis Dimensional Outline

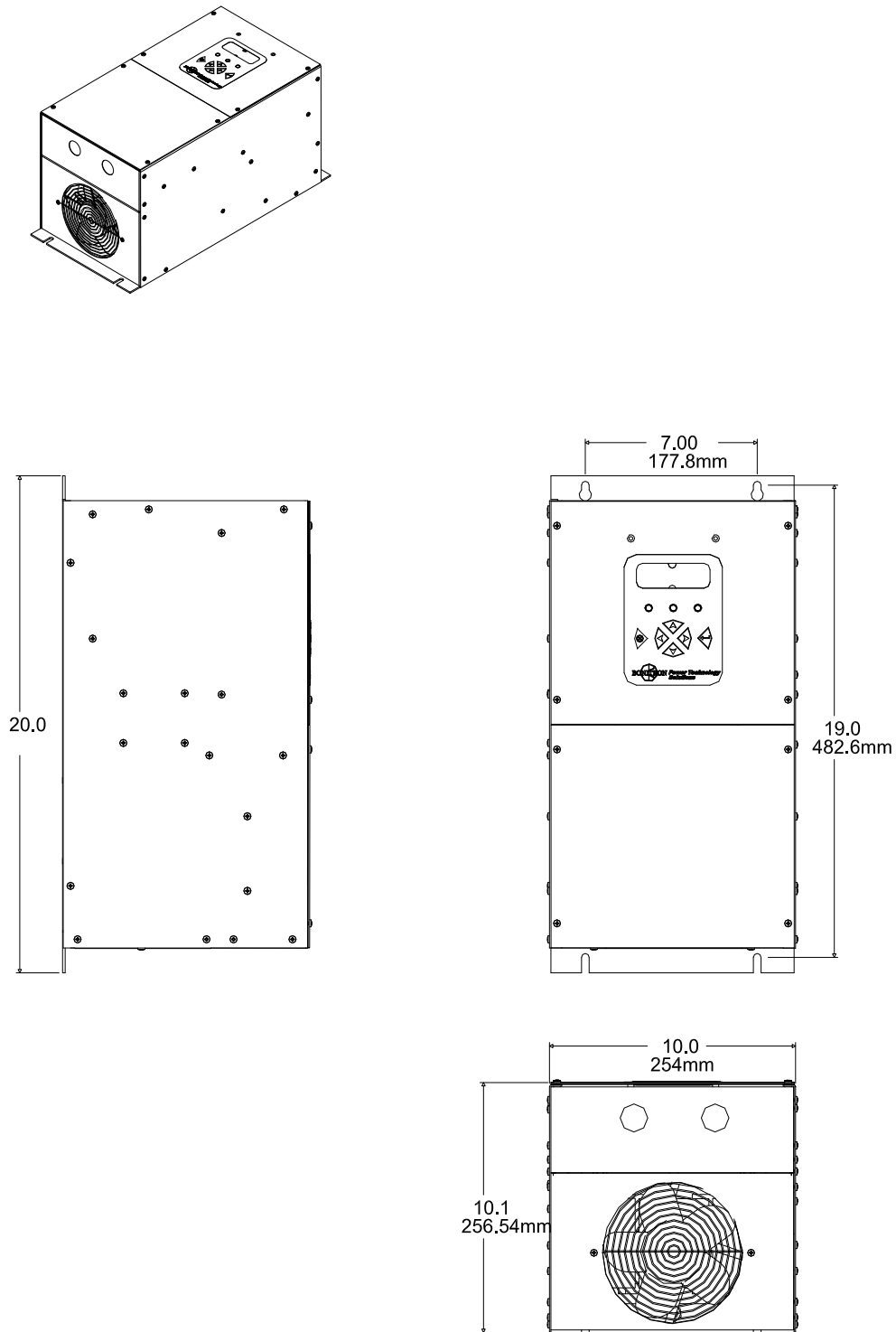

Figure 6-2: M3645P M11 Chassis Dimensional Outline

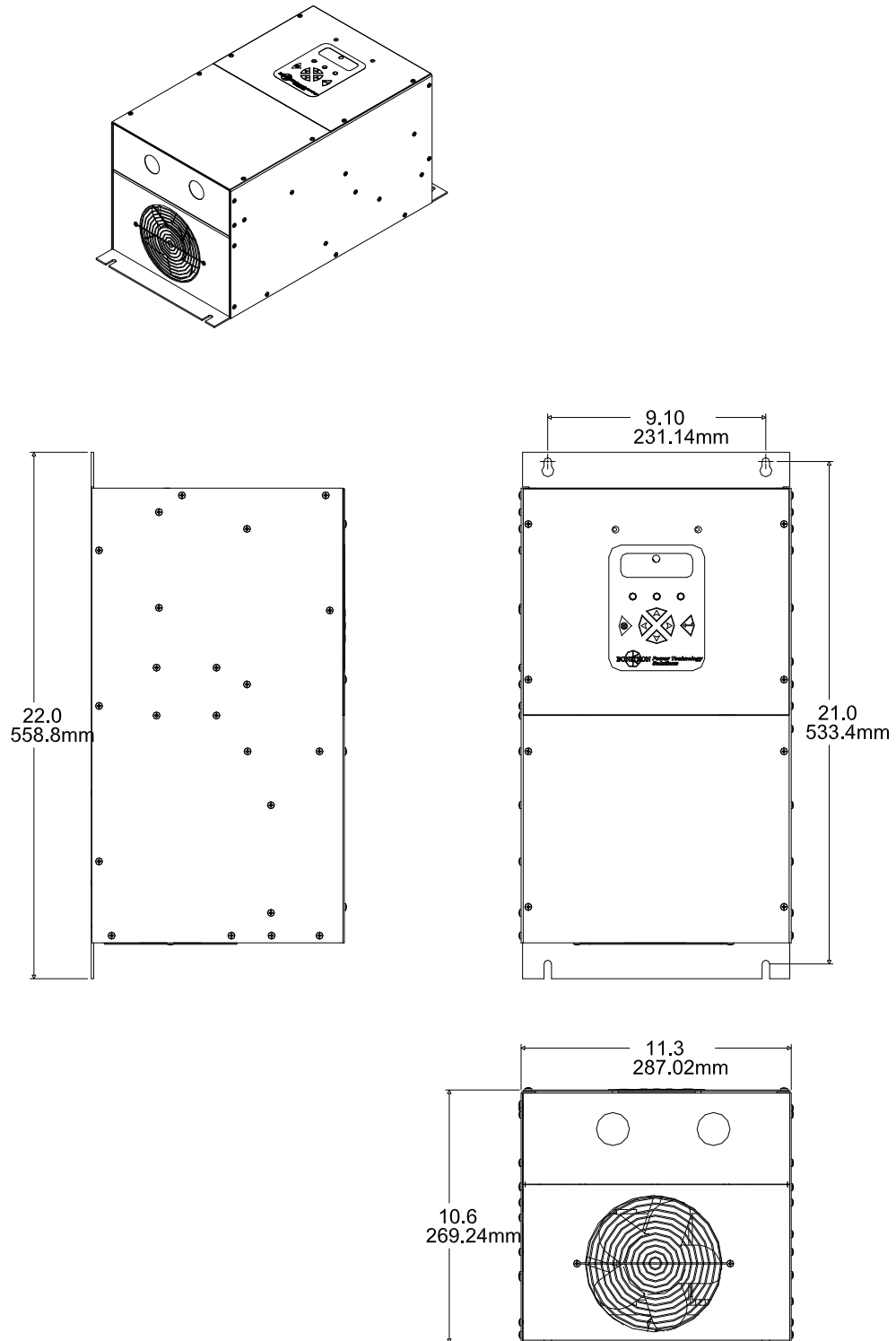

Figure 6-3: M3645P M12 Chassis Dimensional Outline

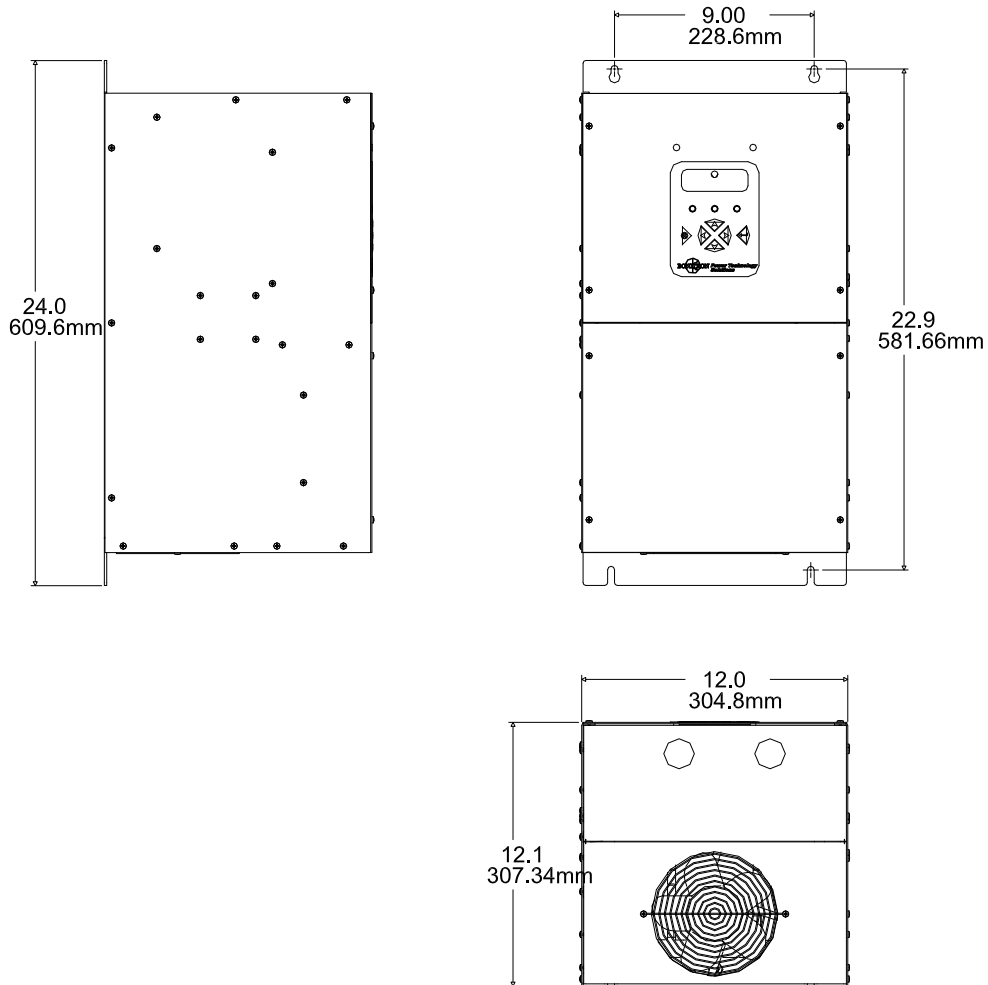
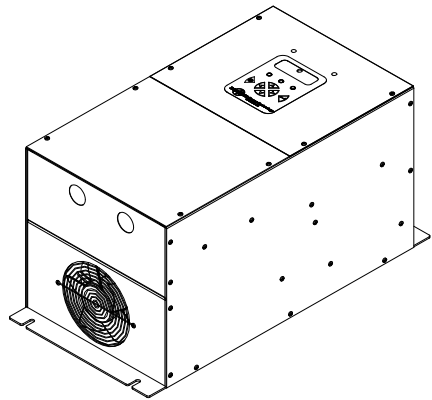

Figure 6-4: M3645P M15 Dimensional Outline

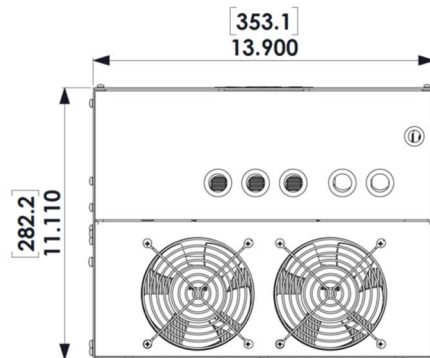
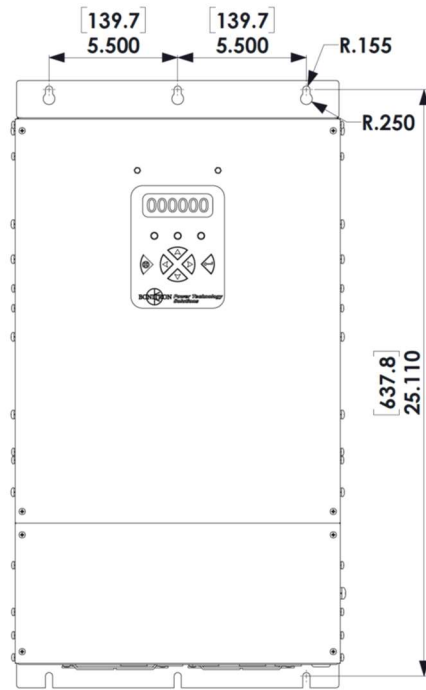
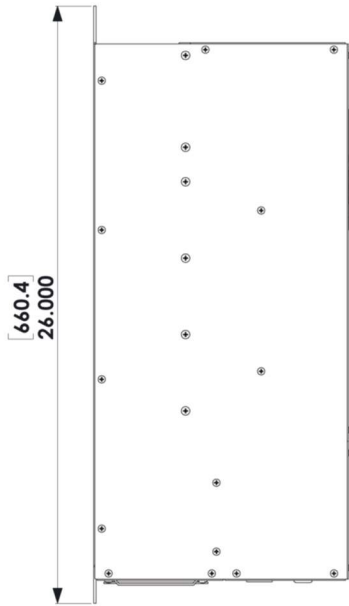
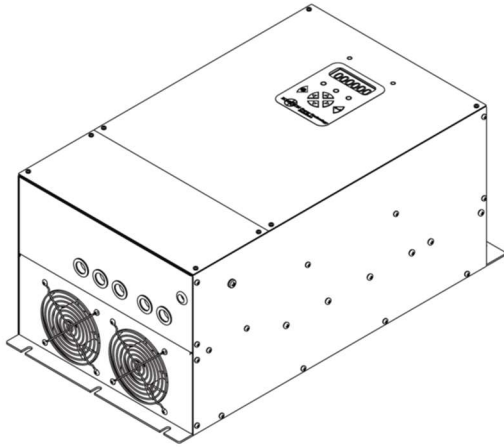

Figure 6-5: M3645 M15 Line Reactor Dimensional Outline

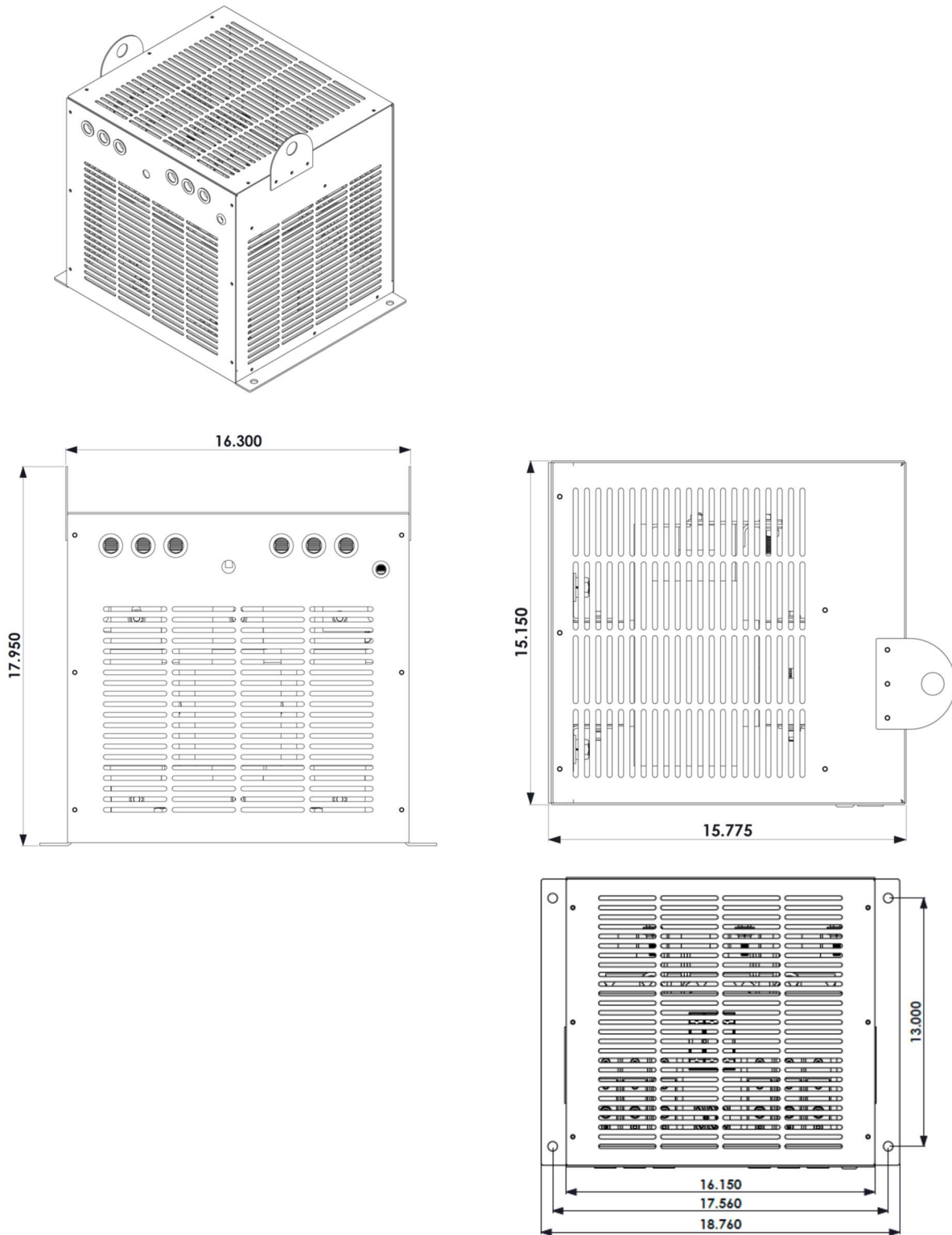
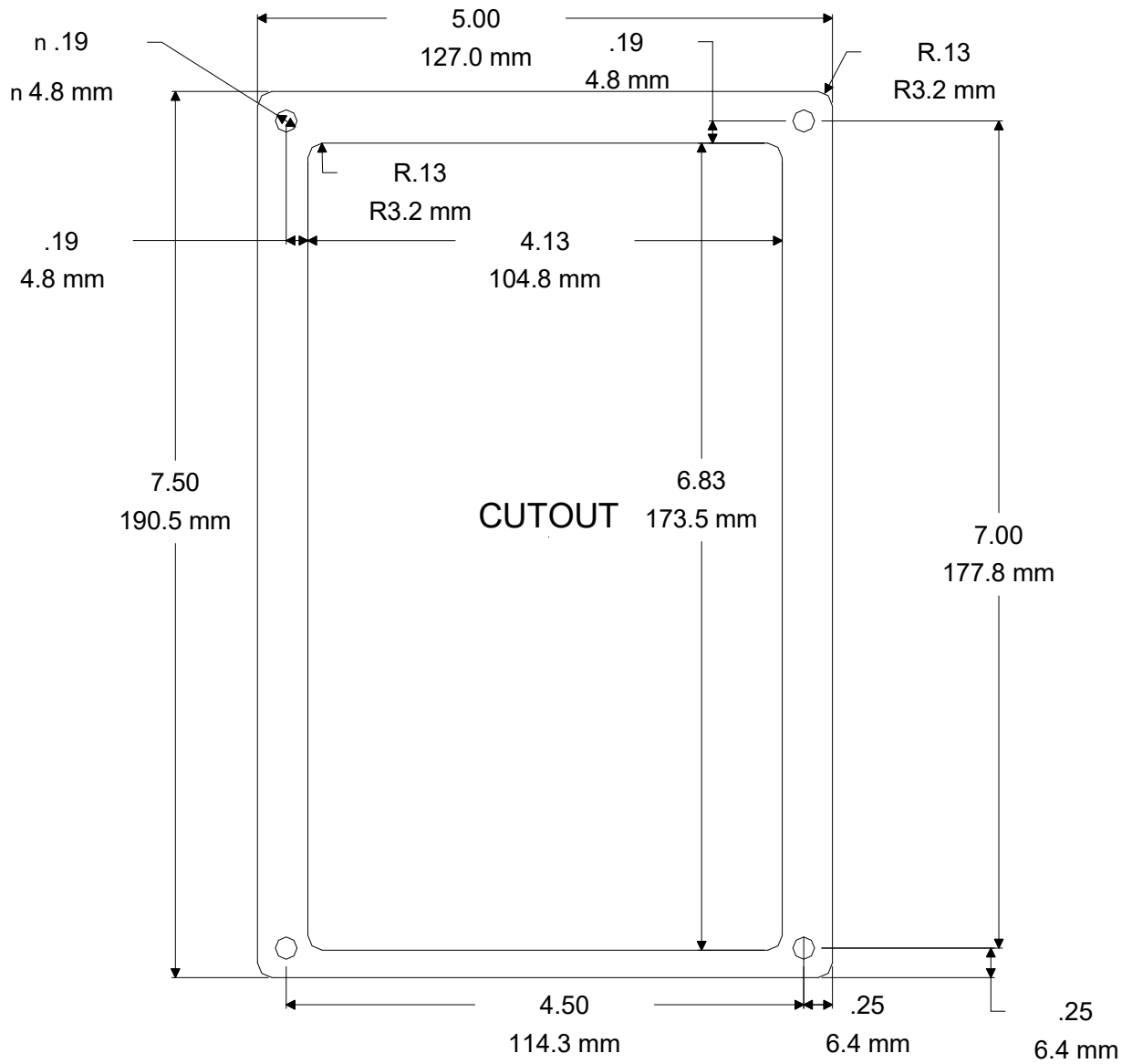
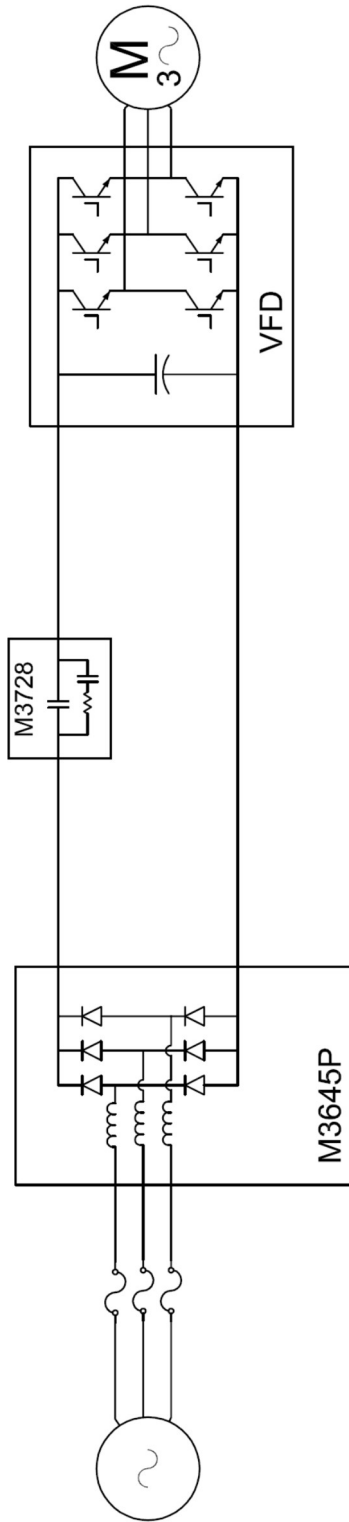

Figure 6-6: KIT 3645DD, External Display Dimensional Outline



6.7. BLOCK DIAGRAM

Figure 6-7: Typical Customer Application



7. APPENDIX

7.1. APPLICATION NOTES

7.1.1. SIZING THE LINE REGENERATION UNIT

The line regeneration unit is sized for the amount of DC bus current, I_{DC} , which it must carry. To obtain the amount of DC bus current needed during deceleration; the load and motor inertias, desired change in RPM, and required stopping time must be known. With these application variables, the following calculations can be made to size the regen. Use the equation below to establish the torque required to decelerate or stop a rotating object.

CALCULATE MOTOR TORQUE

Calculating the motor torque

$$T = \frac{WK^2 \Delta N}{308 t_{on}}$$

Where

T is torque measured in lb·ft.

$$1.0 \text{ lb}\cdot\text{ft} = 1.355818 \text{ Nm}$$

WK^2 is the total inertial load to be decelerated (lb·ft²).

$$1.0 \text{ lb}\cdot\text{ft}^2 = 0.04214011 \text{ kg}\cdot\text{m}^2$$

ΔN is the change in rotational speed (rpm).

308 is a constant

t_{on} is time required to decelerate the load (s).

CALCULATE MOTOR POWER

Calculating the power (HP) regenerated:

$$P = \frac{TN_{max}}{5252}$$

Where

N_{max} is the maximum rotational speed (rpm).

The constant 5252 has units of lb·ft/min/radian.

CALCULATE DC BUS CURRENT

Calculating the regenerated DC bus current, I_{DC} .

$$I_{DC} = \frac{P(746 \frac{W}{HP})}{\sqrt{2}V_{AC}}$$

The DC bus current, I_{DC} , is approximated for the following AC line voltages:

$$\text{For } 230 \text{ V}_{AC} \text{ systems: } I_{DC} = (2.4)P$$

$$\text{For } 380 \text{ V}_{AC} \text{ systems: } I_{DC} = (1.4)P$$

$$\text{For } 460 \text{ V}_{AC} \text{ systems: } I_{DC} = (1.2)P$$

$$\text{For } 575 \text{ V}_{AC} \text{ systems: } I_{DC} = (1.0)P$$

Once I_{DC} is known, you will be able to appropriately size the line regen based upon its current rating.

7.1.2. CALCULATING ENERGY SAVINGS

The regen directs energy from the mechanical load to the power distribution line, where the energy is available to other connected loads. These units provide system energy savings over dynamic braking kits, because the net energy required from the distribution system is reduced by the regenerated energy. Additional savings also come from the lack of a need to provide air conditioning with a dynamic braking kit and from reduced time spent stopping loads.

To calculate the savings, the regeneration duty cycle, the length of operation, the regen HP, and the cost of energy must be known. With these application variables, the following calculation may be made to determine the cost savings:

CALCULATE SAVINGS PER YEAR

Calculating total savings per year in dollars:

$$S = \frac{CP(0.746 \frac{kW}{HP})DHt_{on}}{t_{cycle}}$$

Where

S is Savings per year.

C is the cost in dollars per kW.

P is the regenerated power.

D is the number of days the system is operated.

H is the number of hours per day the system is operated.

t_{on} is the number of seconds per cycle T power is regenerated.

t_{cycle} is the total time to complete a cycle.

SAVINGS EXAMPLE

Assume the following values for this example:

C = \$0.11 per kW

P = 20HP peak, 15HP average during deceleration

D = 365 days

H = 10 hours per day

t_{on} = 5 seconds regen is on

t_{cycle} = 15 seconds

Savings:

$$S = \frac{(\$0.11/kW)(15HP)(0.746 \frac{kW}{HP})(365days)(10hours)(5s)}{(15s)}$$

$$S = \$1497.60$$
