



Model M3575T

Standard Duty Braking Transistor

Customer Reference Manual

Bonitron, Inc.
Nashville, TN



An industry leader in providing solutions for AC drives.

ABOUT BONITRON

Bonitron designs and manufactures quality industrial electronics that improve the reliability of processes and variable frequency drives worldwide. With products in numerous industries, and an educated and experienced team of engineers, Bonitron has seen thousands of products engineered since 1962 and welcomes custom applications.

With engineering, production, and testing all in the same facility, Bonitron is able to ensure its products are of the utmost quality and ready to be applied to your application.

The Bonitron engineering team has the background and expertise necessary to design, develop, and manufacture the quality industrial electronic systems demanded in today's market. A strong academic background supported by continuing education is complemented by many years of hands-on field experience. A clear advantage Bonitron has over many competitors is combined on-site engineering labs and manufacturing facilities, which allows the engineering team to have immediate access to testing and manufacturing. This not only saves time during prototype development, but also is essential to providing only the highest quality products.

The sales and marketing teams work closely with engineering to provide up-to-date information and provide remarkable customer support to make sure you receive the best solution for your application. Thanks to this combination of quality products and superior customer support, Bonitron has products installed in critical applications worldwide.

AC DRIVE OPTIONS

In 1975, Bonitron began working with AC inverter drive specialists at synthetic fiber plants to develop speed control systems that could be interfaced with their plant process computers. Ever since, Bonitron has developed AC drive options that solve application issues associated with modern AC variable frequency drives and aid in reducing drive faults. Below is a sampling of Bonitron's current product offering.

WORLD CLASS PRODUCTS

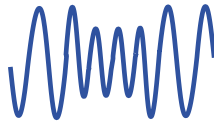

Undervoltage Solutions
Uninterruptible Power for Drives
(DC Bus Ride-Thru)
Voltage Regulators
Chargers and Dischargers
Energy Storage

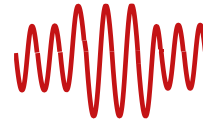

Overvoltage Solutions
Braking Transistors
Braking Resistors
Transistor/Resistor Combo
Line Regeneration
Dynamic Braking for Servo Drives

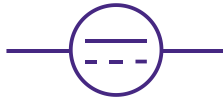

Common Bus Solutions
Single Phase Power Supplies
3-Phase Power Supplies
Common Bus Diodes



Portable Maintenance Solutions
Capacitor Formers
Capacitor Testers

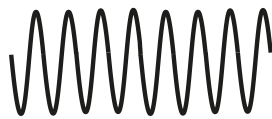

Power Quality Solutions
12 and 18 Pulse Kits



Green Solutions
Line Regeneration

1. INTRODUCTION	7
1.1. Who Should Use	7
1.2. Purpose and Scope	7
1.3. Manual Version and Change Record	7
Figure 1-1: Typical M3575T Module	7
1.4. Symbol Conventions Used in this Manual and on Equipment	8
2. PRODUCT DESCRIPTION	9
2.1. Related Products	9
2.2. Part Number Breakdown	9
Figure 2-1: Example of M3575T Part Number Breakdown	9
Table 2-1: AC Voltage Rating Codes	9
Table 2-2: Chassis Determination	10
Table 2-3: Special Options	11
2.3. General Specifications	11
Table 2-4: General Specifications Table	11
2.4. General Precautions and Safety Warnings	12
3. INSTALLATION INSTRUCTIONS	13
3.1. Environment	13
3.2. Unpacking	13
3.3. Mounting	13
3.4. Conduit Cover Installation for M3 and M4 Chassis	13
Figure 3-1: Conduit Cover Installation for M3 and M4 chassis	14
3.5. Wiring and Customer Connections	14
3.5.1. Power Wiring	14
Table 3-1: Power Wiring Specifications	15
3.5.2. Control Interface Wiring	16
Table 3-2: Control Interface Wiring Specifications	16
3.5.3. Terminal Connectors	17
Figure 3-2: 15, 30 & 75 Amp Units	17
Figure 3-3: 150 Amp Units	17
Figure 3-4: 200 and 300 Amp Units	18
Figure 3-5: 600 Amp Units	18
Figure 3-2: Typical Power Interconnection Diagram	19
Figure 3-6: Customer Connections	20
4. OPERATION	21
4.1. Functional Description	21
4.2. Features	21
4.2.1. Indicators	21
4.2.2. Terminal Strip I/O	21
4.3. Pre-Power Checks	22
4.4. Startup Procedure and Checks	22
4.5. Operational Adjustments	22
5. MAINTENANCE AND TROUBLESHOOTING	23
5.1. Periodic Testing	23
5.2. Maintenance Items	23
5.3. Troubleshooting	23
5.3.1. DC bus light not illuminated	23
5.3.2. Blown DC bus fuse	24
5.3.3. Fan runs constantly	24
5.3.4. Fan doesn't run	24
5.3.5. Control Ready contacts won't close	25

Table of Contents

5.3.6.	Module over-temp, or module seems too hot	25
5.3.7.	Drive trips on overvoltage	25
5.3.8.	Braking light flickers	25
5.3.9.	Active braking light stays on all the time	26
5.3.10.	Attached Drive Will Not Precharge	26
5.4.	Technical Help – Before you call	26
6.	ENGINEERING DATA	27
6.1.	Ratings Charts.....	27
	Table 6-1: Module Ratings	27
6.2.	Watt Loss	28
	Table 6-2: Watt Loss	28
6.3.	Certifications.....	29
6.4.	UL 508A Short Circuit Current Rating	29
6.5.	Fuse Sizing and Rating.....	29
	Table 6-3: Recommended Fuses	29
6.6.	DC Bus Length Limits.....	30
	Table 6-4: Maximum Inductance for DC Link Cable	30
6.7.	Dimensions and Mechanical Drawings	31
	Figure 6-1: M3 Chassis Dimensional Outline Drawing	31
	Figure 6-2: M4 Chassis Dimensional Outline Drawing	32
	Figure 6-3: B5 Chassis Dimensional Outline Drawing	33
	Figure 6-4: B7 Chassis Dimensional Outline Drawing	34
	Figure 6-5: MTW 3575-CVR-30U Conduit Cover Dimensional Outline	35
	Figure 6-6: MTW 3575-CVR-30 Conduit Cover Dimensional Outline	35
6.8.	Block Diagram	36
	Figure 6-7: Block Diagram	36
7.	APPENDIX.....	37
7.1.	Application Notes.....	37
7.1.1.	Sizing Your Braking Requirements.....	37
7.1.2.	Status Contact Connection Notes	38
	Figure 7-1: Typical Status Contact Wiring with Input Contactor.....	40
	Figure 7-2: Typical Status Contact Wiring with Drive Interlock Control	41
7.1.3.	Common Bus Notes.....	42

This page is intentionally left blank.

1. INTRODUCTION

1.1. WHO SHOULD USE

This manual is intended for use by anyone who is responsible for integrating, installing, maintaining, troubleshooting, or using this equipment with any AC drive system.

Please keep this manual for future reference.

1.2. PURPOSE AND SCOPE

This manual is a user's guide for the M3575T standard duty braking transistor. It will provide the user with the necessary information to successfully install, integrate, and use the M3575T.

In the event of any conflict between this document and any publication and/or documentation related to the AC drive system, the latter shall have precedence.

1.3. MANUAL VERSION AND CHANGE RECORD

A new setpoint option and additional dimensional outlines were added in rev 07a.

Connection drawings were updated in rev 07b.

Wiring specifications were updated in rev 07c.

Updates to the Indicators were made in rev 07d.

The manual template was updated in rev 07e.

Table 6-1 and Figure 6-4 were updated in rev 07f.

Table 6-1 and Section 7.1.1.3 were updated in rev 07g.

Tables 2-2 and 3-1 and Figure 6-3 were updated in rev 07h.

Section 4.2.21 Status Contacts was updated in rev 07i.

Information regarding conduit cover installation was added in rev 07j.

Updates to Table 2-4 were made in rev 07k.

Update to Section 3.5.1.1 in rev 07m.

Updated Section 5.3.3 and 5.3.4 in rev 07n.

Add drawings of terminal connections in rev 07p.







Updated Table 6-1 in rev 07q.

Updated Table 6-3 in rev 07r.

Figure 1-1: Typical M3575T Module



Symbol Conventions Used in this Manual and on Equipment

	<p>Earth Ground or Protective Earth</p>
	<p>AC Voltage</p>
	<p>DC Voltage</p>
 <p>DANGER!</p>	<p>Electrical Hazard - Identifies a statement that indicates a shock or electrocution hazard that must be avoided.</p>
 <p>DANGER!</p>	<p>DANGER: Identifies information about practices or circumstances that can lead to personal injury or death, property damage, or economic loss.</p>
 <p>CAUTION!</p>	<p>CAUTION: Identifies information about practices or circumstances that can lead to property damage, or economic loss. Attentions help you identify a potential hazard, avoid a hazard, and recognize the consequences.</p>
 <p>CAUTION!</p>	<p>Heat or burn hazard - Identifies a statement regarding heat production or a burn hazard that should be avoided.</p>

2. PRODUCT DESCRIPTION

The need for regenerated voltage control occurs in applications where the frequency of an AC motor at times exceeds that of its adjustable speed drive. In this case, the motor acts as a generator. The energy generated by the motor must be dissipated as heat, or returned to the power line. If this energy is not controlled, the motor may run with high peak voltages, the energy may be dissipated as heat in the motor, or the drive may trip on an over-voltage condition.

For applications where this condition occurs infrequently, dissipating the energy as heat through resistive braking control can be the most cost-effective solution.

2.1. RELATED PRODUCTS

The model M3575T series of braking products is designed to provide resistive braking control for applications utilizing a standard AC drive with a fixed DC bus. These modules have been designed for use with remotely mounted resistive loads such as the model M3575R or M3775RK resistive load modules.

For higher duty cycle applications, consider the M3452 series of braking transistor modules.

2.2. PART NUMBER BREAKDOWN

Figure 2-1: Example of M3575T Part Number Breakdown

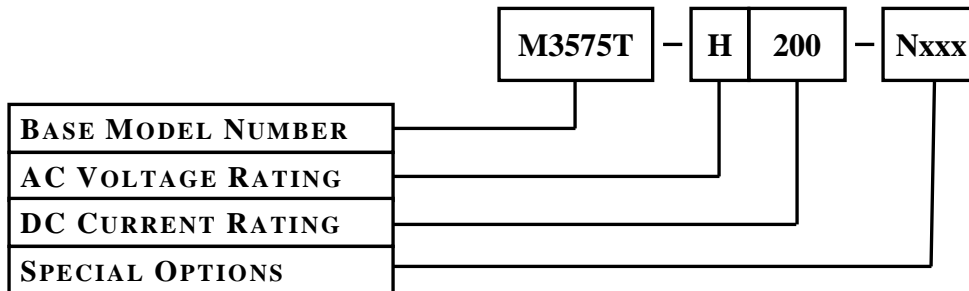

BASE MODEL NUMBER

The Base Model Number **M3575T** indicates that the unit incorporates the braking transistor and its control circuitry only. An external resistive load is required for proper function of the braking module.

AC VOLTAGE RATING

The AC voltage rating of the braking unit should match the input AC line voltage to the AC drive used with the braking module. This rating is represented by a letter code as shown in Table 2-1.

Table 2-1: AC Voltage Rating Codes

AC VOLTAGE RATING CODE	AC VOLTAGE NOMINAL AC LINE	DC BUS TRIGGER LEVEL
L	230VAC	375VDC
E	400VAC	620VDC
H	460VAC	750VDC

DC CURRENT RATING

The DC current rating indicates the maximum DC current level safely handled by the braking unit. This rating is represented numerically such that a value of “15” would indicate that the braking unit has a peak current rating of 15 amps DC. The RMS current rating of the unit depends on the application of the braking module. RMS current ratings have been calculated for braking as well as for overhauling applications. See Section 7.1.1 for application sizing assistance.

CHASSIS INFORMATION

Chassis size is determined by the module rating. For additional information, please see Table 6-1 for ratings charts and Table 6-4 for chassis dimensions.

Table 2-2: Chassis Determination

230VAC

MODEL NUMBER	CHASSIS	DIMENSIONS H" x W" x D"
M3575T-L15	M3	12.75 x 3.00 x 8.70
M3575T-L30	M3	12.75 x 3.00 x 8.70
M3575T-L60	M4	12.75 x 4.00 x 8.70
M3575T-L125	B5	17.75 x 5.50 x 8.00
M3575T-L150	B5	17.75 x 5.50 x 8.00
M3575T-L200	B7	17.75 x 7.00 x 8.00
M3575T-L300	B7	17.75 x 7.00 x 8.00
M3575T-L600	B7	17.75 x 7.00 x 8.00

400VAC

MODEL NUMBER	CHASSIS	DIMENSIONS H" x W" x D"
M3575T-E15	M3	12.75 x 3.00 x 8.70
M3575T-E30	M3	12.75 x 3.00 x 8.70
M3575T-E75	M4	12.75 x 4.00 x 8.70
M3575T-E125	B5	17.75 x 5.50 x 8.00
M3575T-E150	B5	17.75 x 5.50 x 8.00
M3575T-E200	B7	17.75 x 7.00 x 8.00
M3575T-E300	B7	17.75 x 7.00 x 8.00
M3575T-E600	B7	17.75 x 7.00 x 8.00

460VAC

MODEL NUMBER	CHASSIS	DIMENSIONS H" x W" x D"
M3575T-H15	M3	12.75 x 3.00 x 8.70
M3575T-H30	M3	12.75 x 3.00 x 8.70
M3575T-H75	M4	12.75 x 4.00 x 8.70
M3575T-H125	B5	17.75 x 5.50 x 8.00
M3575T-H150	B5	17.75 x 5.50 x 8.00
M3575T-H200	B7	17.75 x 7.00 x 8.00
M3575T-H300	B7	17.75 x 7.00 x 8.00
M3575T-H600	B7	17.75 x 7.00 x 8.00

SPECIAL OPTIONS

Table 2-3: Special Options

CODE	DESCRIPTION
Nxxx	A 3 digit setpoint is entered when a non-standard setpoint is required
C	Optional conduit cover for M3 and M4 chassis only.

2.3. GENERAL SPECIFICATIONS

Table 2-4: General Specifications Table

PARAMETER	SPECIFICATION
Adjustments	Factory calibrated - no field adjustments necessary
Connections	Drive DC bus Resistors Fault contact
Enclosure	Type 1
Status Output	Form-C contact rated at 1.0 Amp at 24VDC or 0.5 Amp at 120VAC – Normally closed Status Output opens on: <ul style="list-style-type: none"> • Open load • Over temperature • Transistor failure
Panel Indicators	DC Bus Active Braking
Drive Voltage	For use with 230VAC, 400VAC, and 460VAC drive systems
Control Power	Derived from DC bus voltage: <ul style="list-style-type: none"> • 100-400VDC required for 230VAC drives • 320-800VDC required for 400VAC drives • 450-800VDC required for 460VAC drives
Braking Current	15 – 600A (Use Bonitron M3452 for applications requiring 600+ Amps)
Turn-on Voltage	375VDC (for 230VAC drives) 620VDC (for 400VAC drives) 750VDC (for 460VAC drives)
Maximum On-Time	60 seconds
Duty Cycle	20% maximum for braking applications 6.67% maximum for overhauling applications (Use Bonitron M3452 for applications requiring higher duty cycles)
UL Approval	Units rated up to and including 75 amps peak are UL approved Refer to UL file number E204386
Operating Temp	0°C to 40° C
Storage Temp	-20 °C to +65°C
Installation Environment	<ul style="list-style-type: none"> • Normally only nonconductive pollution occurs. • Recommended humidity: <90% non-condensing.

2.4. GENERAL PRECAUTIONS AND SAFETY WARNINGS



DANGER!

- **HIGH VOLTAGES MAY BE PRESENT!**
- **NEVER ATTEMPT TO OPERATE THIS PRODUCT WITH THE ENCLOSURE COVER REMOVED!**
- **FAILURE TO HEED THESE WARNINGS MAY RESULT IN SERIOUS BODILY INJURY OR DEATH!**



CAUTION!

- **THIS PRODUCT WILL GENERATE HIGH AMBIENT TEMPERATURES DURING OPERATION.**
- **THIS PRODUCT SHOULD BE INSTALLED ACCORDINGLY ON NON-FLAMMABLE SURFACES WITH CLEARANCES OF AT LEAST TWO INCHES IN ALL DIRECTIONS.**
- **ALWAYS ALLOW AMPLE TIME FOR THE UNIT TO COOL BEFORE ATTEMPTING SERVICE ON THIS PRODUCT.**
- **NO USER-SERVICEABLE PARTS ARE CONTAINED WITHIN THIS PRODUCT. INOPERABLE UNITS SHOULD BE REPLACED OR RETURNED FOR EVALUATION AND/OR REPAIR BY QUALIFIED TECHNICIANS.**
- **BEFORE ATTEMPTING INSTALLATION OR REMOVAL OF THIS PRODUCT, BE SURE TO REVIEW ALL DRIVE AND/OR RESISTIVE LOAD DOCUMENTATION FOR PERTINENT SAFETY PRECAUTIONS.**
- **INSTALLATION AND/OR REMOVAL OF THIS PRODUCT SHOULD ONLY BE ACCOMPLISHED BY A QUALIFIED ELECTRICIAN IN ACCORDANCE WITH NATIONAL ELECTRICAL CODE OR EQUIVALENT REGULATIONS.**



ATTENTION!

Important Notice about drives with DC link chokes!

- **DURING BRAKING SITUATIONS, ENERGY STORED IN A DRIVE'S DC LINK CHOKES CAN CREATE EXTREME OVER-VOLTAGE CONDITIONS FOR BRAKING TRANSISTOR MODULES. TO AVOID THESE CONDITIONS, DC CONNECTIONS FROM BRAKING TRANSISTOR MODULES TO THE DRIVE SYSTEM SHOULD ALWAYS BE MADE DIRECTLY IN PARALLEL WITH THE DRIVE'S FILTER CAPACITORS. THESE MODULES SHOULD NEVER BE CONNECTED IN SERIES WITH A DRIVE'S DC LINK CHOKES.**
- **BE SURE TO REVIEW ALL PERTINENT AC DRIVE DOCUMENTATION TO ENSURE THAT THE PROPER CONNECTIONS ARE USED.**
- **CONTACT THE DRIVE MANUFACTURER OR EQUIPMENT SUPPLIER FOR ASSISTANCE WITH DRIVE CONNECTIONS.**

ANY QUESTIONS AS TO APPLICATION, INSTALLATION, OR SERVICE SAFETY SHOULD BE DIRECTED TO THE EQUIPMENT SUPPLIER.

3. INSTALLATION INSTRUCTIONS

3.1. ENVIRONMENT

The installation site for the module should be chosen with several considerations in mind.

- The mounting surface must be non-flammable, as the unit will generate high ambient temperatures during typical operation.
- The unit will require a minimum clearance of two inches in all directions around it.
- The unit will require adequate protection from the elements.

3.2. UNPACKING

Prior to installation, please verify that the product received matches the product that was ordered and that there is no physical damage to the unit. If the wrong product was received or is damaged in any way, please contact the supplier from which it was purchased.

3.3. MOUNTING



Installation and/or removal of this product should only be accomplished by a qualified electrician in accordance with National Electrical Code or equivalent regulations.

Proper installation of the Model M3575T standard duty braking transistor module should be accomplished following the steps outlined below. Be sure to refer to your AC drive's instruction manual as you perform these steps. Please direct all installation inquiries that may arise during the installation and startup of this braking product to your supplier or system integrator.

Once the installation site has been selected as outlined in Section 3.1, the unit should be mounted in place using two or four ¼ inch diameter bolts or studs. Mounting dimensions vary by unit chassis size. Refer to Table 2-2 and Section 6.7 for unit and mounting dimensions.

3.4. CONDUIT COVER INSTALLATION FOR M3 AND M4 CHASSIS

The conduit cover is an optional cover for the M3575T with current ratings 15, 30, 60, and 75A. The conduit cover option is designated by **C** in the part number. See Section 6.4 for conduit cover dimensions.

1. Inspect the chassis and conduit cover metalwork, MTW 3575-CVR-30 and MTW 3575-CVR-30U.
2. Install MTW 3575-CVR-30U below terminal strip. Rout wires through the circular opening.
3. Install MTW 3575-CVR-30 according to Figure 3-2.

Figure 3-1: Conduit Cover Installation for M3 and M4 chassis

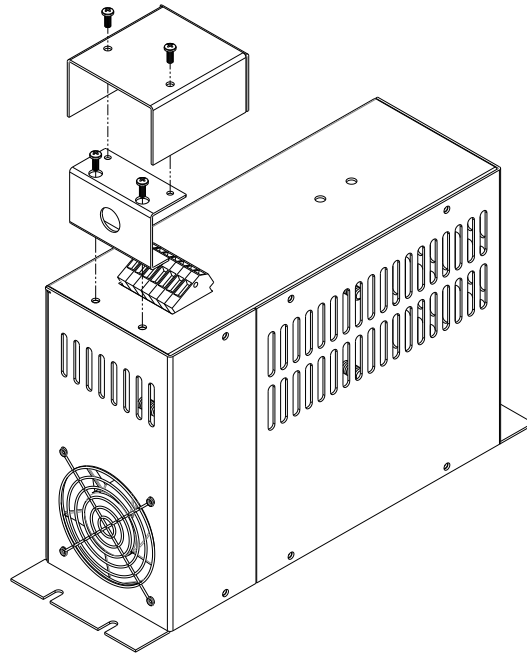

3.5. WIRING AND CUSTOMER CONNECTIONS

3.5.1. POWER WIRING

This section provides information pertaining to the field connection of the DC bus inputs to the M3575T and M3575R resistive braking modules. Actual connection points and terminal numbers for the AC drive module will be found in the documentation provided with the drive. Be sure to review all pertinent drive and system documentation as well as the power connection notes listed below before proceeding.



Only qualified electricians should perform and maintain the interconnection wiring of this product. All wiring should be done in accordance with local codes.

Table 3-1: Power Wiring Specifications

MODEL NUMBER	CHASSIS	TERMINAL	MIN WIRE AWG	MAX WIRE AWG	TORQUE
M3575T-L15 M3575T-L30 M3575T-L60 M3575T-E15 M3575T-E30 M3575T-E75 M3575T-H15 M3575T-H30 M3575T-H75	M3, M4	DC+, DC-, RES+, RES-	16 AWG	12 AWG	0.4-0.6 Nm 3.5-5.3 lb-in
M3575T-L125 M3575T-L150 M3575T-E125 M3575T-E150 M3575T-H125 M3575T-H150	B5	DC+, DC-, RES+, RES-	12 AWG	8 AWG	0.8-1.6 Nm 7-14 lb-in
M3575T-L200 M3575T-L300 M3575T-E200 M3575T-E300 M3575T-H200 M3575T-H300	B7 (200A, 300A)	DC+, DC-, RES+, RES-	6 AWG	2 AWG	2.5-5.0 Nm 22-44 lb-in
M3575T-L600 M3575T-E600 M3575T-H600	B7 (600A)	DC+, DC-, RES+, RES-	4 AWG	2/0 AWG	14 Nm 120 lb-in



Attention!

The braking kit is rated in peak amperage. The wiring only needs to be sized to handle the RMS current value which can be found in Table 6-1 in Section 6 of this manual.

3.5.1.1. DC BUS CONNECTION



WARNING!

- *DC bus polarity must be correct! Connecting the DC bus with the polarity reversed will cause damage to the equipment!*
- *On 15, 30, 60, and 75 amp units, the drive's DC bus connections must be downstream of the precharge circuit.*

- As a general rule, 30 feet (10m) is the maximum total buswork or cable that the chopper should be mounted from the drive. This means that the actual installation distance should be 15 feet (5m), as the cable must go out and back. If you must connect the choppers farther away, see Section 6.6 DC Bus Length Limits.
- The braking transistor must be connected directly to the DC bus filter capacitors of the drive. **When using 15, 30, 60, and 75 amp units, ensure there is no precharge circuit in between the bus capacitors and the M3575T.**
- Figure 3-2 is an example of the terminals that may be available in your installation. Not all of the terminals may be on your drive. Refer

to the drive manufacturer's manual or technical documents to locate the proper terminals. Your drive will have different terminal markings depending on manufacturer and drive series.

- Ensure that the polarity of the connection is correct. Incorrect polarity will effectively short the DC bus of the drive, and can cause severe damage to the drive, load resistor, and the braking transistor.
- The proper terminals to attach the braking transistor are marked + and - on Figure 3-2.
- The terminals marked BR+ and BR- are intended for the internal braking transistor. If the Bonitron external braking transistor is hooked to the terminals, the braking transistor will not operate properly. In some cases, it may cause drive failure.
- The terminals marked X and Y are intended for connection of a DC link choke. If the Bonitron braking transistor is connected to the terminals marked X and Y in Figure 3-2, switching resonances caused by the DC link choke will destroy the braking transistor. If the Bonitron braking transistor is connected between X and Y, the drive will not operate.
- If the braking transistor is connected to the terminals marked A and B in Figure 3-2, switching resonances caused by the lack of filter capacitance during precharge will destroy the braking transistor.

3.5.1.2. RESISTOR CONNECTION

The polarity of the resistor connections is not critical; however, it is critical that the resistor be connected to the proper terminals. Improper hookup can lead to the resistor being connected directly across the DC bus, which will cause severe overheating and drive stress.

Minimum load resistance requirements listed in Table 6-1: Module Ratings in Section 6 of this manual MUST be followed when selecting a resistive load for use with the M3575T unit.

3.5.1.3. GROUNDING REQUIREMENTS

All units come equipped with either a ground terminal or ground stud that is connected to the module chassis. Ground the chassis in accordance with local codes. Typically, the wire gauge will be the same as is used to ground the attached drive.

3.5.2. CONTROL INTERFACE WIRING

Table 3-2: Control Interface Wiring Specifications

TERMINAL	FUNCTION	ELECTRICAL SPECIFICATIONS	MIN WIRE AWG	MAX WIRE AWG	TORQUE
TS 5-6	Status Contacts	1.0 A at 24 VDC 0.5 A at 120 VAC	16 AWG	12 AWG	0.4-0.6 Nm 3.5-5.3 lb-in

3.5.3. TERMINAL CONNECTORS

Figure 3-2: 15, 30 & 75 Amp Units

DC +	BUS -	RES	RES	FAULT ALARM	GND	
1	2	3	4	5	6	7

Figure 3-3: 150 Amp Units

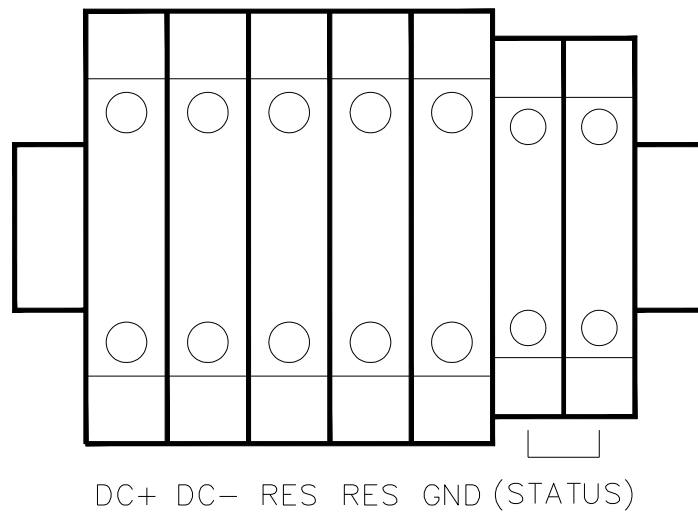

Figure 3-4: 200 and 300 Amp Units

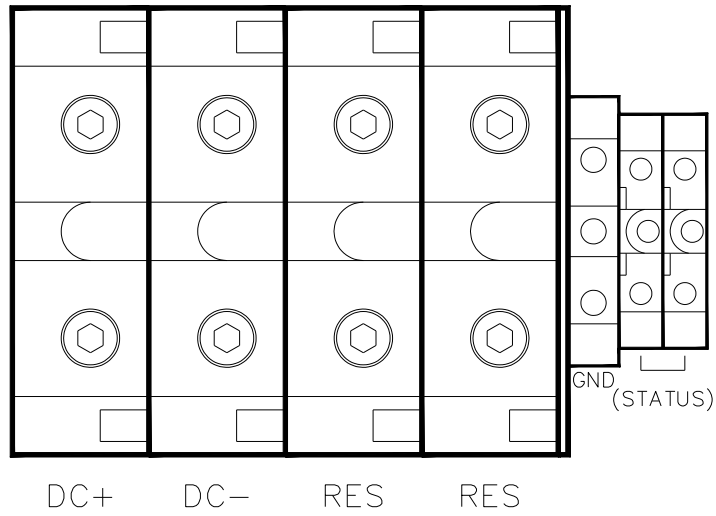

Figure 3-5: 600 Amp Units

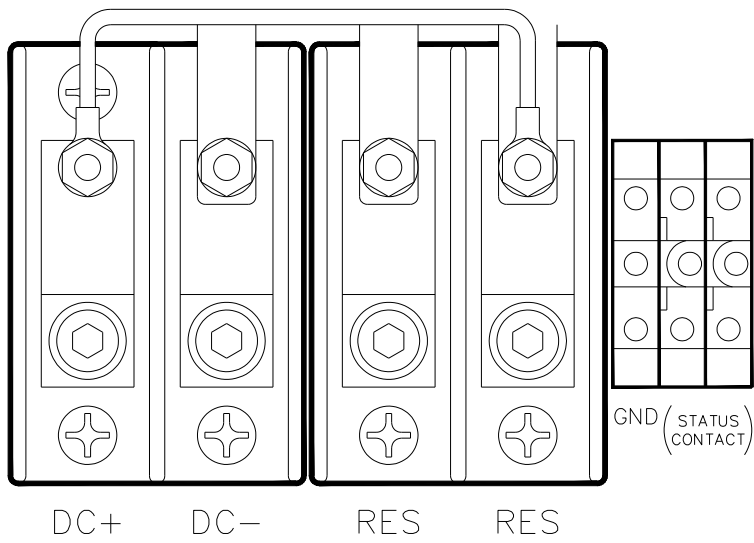

Figure 3-2: Typical Power Interconnection Diagram

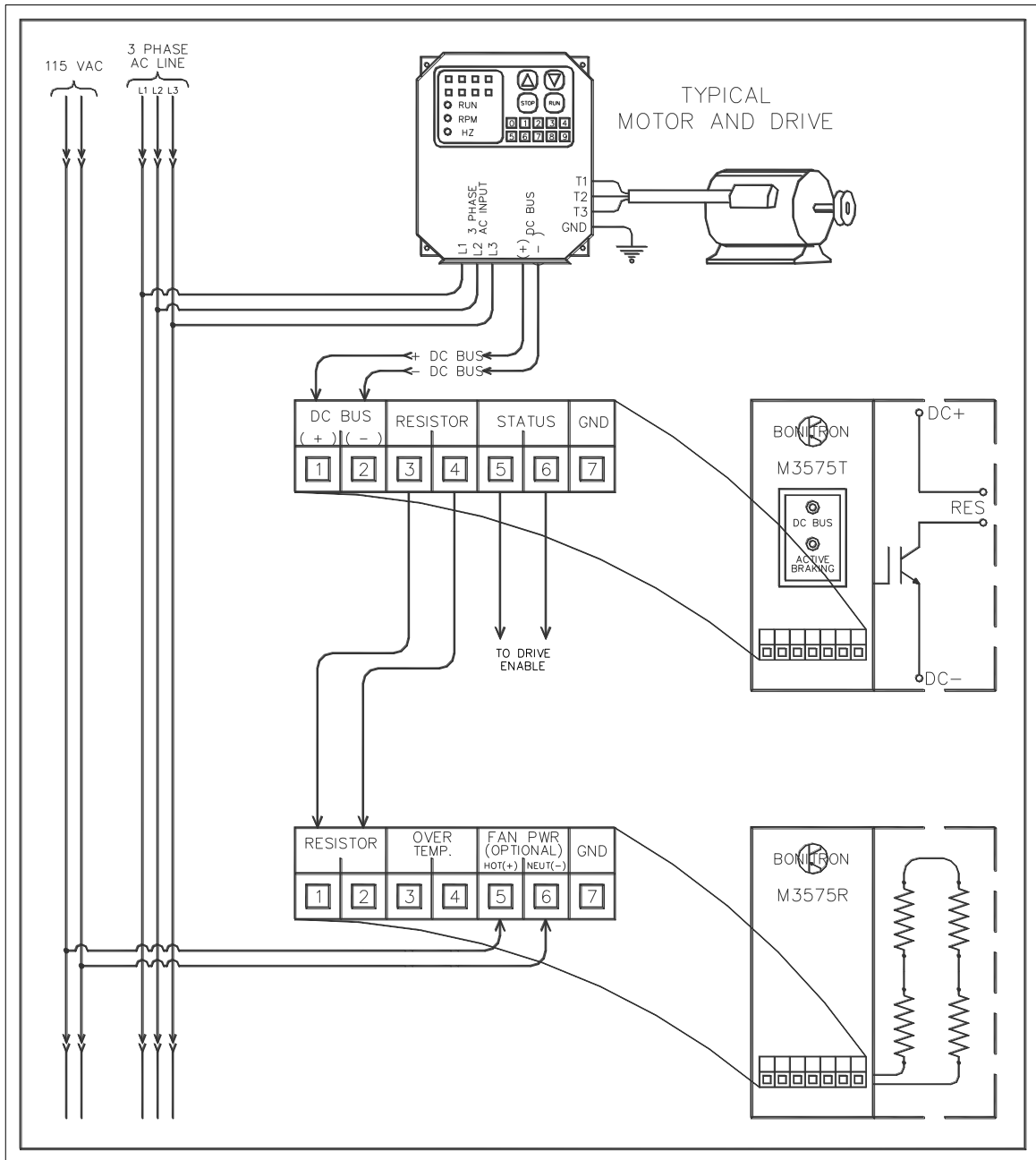
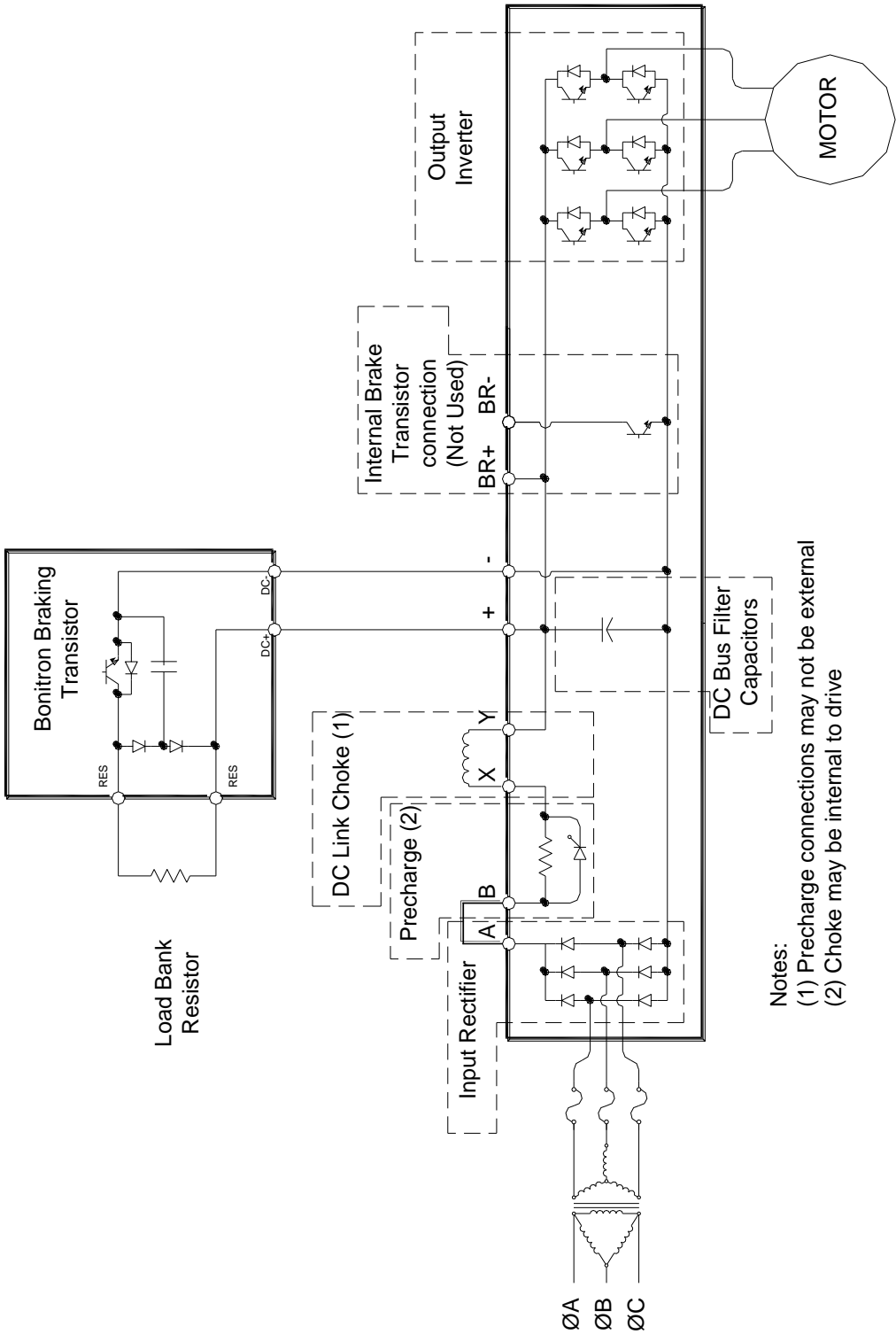

Figure 3-6: Customer Connections



Notes:
 (1) Precharge connections may not be external
 (2) Choke may be internal to drive

4. OPERATION

4.1. FUNCTIONAL DESCRIPTION

The M3575T module controls the bus voltage of a variable frequency drive by transferring energy to a resistor.

When the drive's DC bus voltage exceeds a fixed setpoint, the dynamic braking transistor module's control electronics turns on an IGBT transistor connecting a resistive load across the DC bus. When the DC bus drops below another threshold, the IGBT turns off.

The standard turn on setpoint for the M3575T is 375VDC for 230VAC systems, 620VDC for 400VAC systems, and 750VDC for 460VAC systems. See Section 2.2 Special Options for non-standard turn on voltages.

4.2. FEATURES

4.2.1. INDICATORS

4.2.1.1. DC BUS

The green DC Bus indicator illuminates when the voltage between the DC+ and DC- terminals is greater than 40VDC.



*Do not use this light as an indication that the DC Bus is safe to work on! **Always** check the DC bus with a working voltmeter before servicing equipment, as the DC bus light may be broken!*

4.2.1.2. ACTIVE BRAKING

The red indicator illuminates when the chopper IGBT is on. When the drive is idle, this light should not be on. During braking, this light will be on or flashing, depending on the amount of braking energy.

4.2.2. TERMINAL STRIP I/O

See Figure 3-1.

4.2.2.1. STATUS CONTACTS

- The Status Contacts TS 5&6 will be closed unless there is a fault.
- These contacts OPEN on the following conditions:
 - Failed IGBT (power transistor)
 - Open Load
 - Overtemperature in module

If one of these conditions exists, the module will not operate, and the DC bus will not be regulated through the braking resistor.



Bonitron braking transistor modules are designed to be used with stand-alone or common DC bus drive/inverter systems with bus capacitors. When using the Bonitron modules on common bus systems, special considerations may apply. Refer to and review the Application Notes found in Section 7.1.3 prior to energizing this type of system!

4.3. PRE-POWER CHECKS

Ensure that all connections are tight, DC bus polarity is correct, and that all customer wiring is of the proper size for operational requirements. Check for exposed conductors that may lead to inadvertent contact. Verify the load bank is properly sized for the application. The ohmic value and wattage rating of the load bank are important for proper and reliable system operation! ***Remember; do not operate the module with less than its minimum ohms value rating!*** See Section 7 for sizing information.

4.4. STARTUP PROCEDURE AND CHECKS

Apply AC power to the drive system and the dynamic braking transistor module. Do not start the motors on the system.

On the dynamic braking transistor module, verify the following:

- Green **DC Bus** indicator is **ON**.
- Red **Active Braking** indicator is **OFF!** **Immediately** turn off all power if the indicator is **ON** to avoid possible load bank overheating and/or other equipment damage
- Verify the drive system DC bus voltage, and make sure it is within tolerance for the drive system.
- Verify the DC current flow through the load bank is zero amps. Even though the Red **Active Braking** indicator is **OFF**, any significant current flow could indicate incorrect connections or damaged equipment. ***Immediately turn off all power to avoid possible load bank overheating and/or other equipment damage if current flow is indicated!***
 - Note: Depending on the type of measuring equipment used, small currents could just be noise pickup and could be ignored.
- Check status contacts to ensure they are all closed. This indicates that the module does not have a fault.

If any of the above conditions are not as indicated, turn off all power and allow ample time for all system energy sources to discharge. **Verify that all voltages are below 40V with a meter!** Check all wiring connections. Refer to the Section 5 of this manual for more information. For further assistance, contact Bonitron.

Once the pre-checks are complete, the drive system can be enabled. Once the drive system is operational, run the motors with light deceleration, and decrease the braking time until the red **Active Braking** indicator lights.

4.5. OPERATIONAL ADJUSTMENTS

No adjustments are necessary for this module. All regulation points are factory adjusted, and should not be changed in the field. If your module is not functioning properly, refer to troubleshooting in Section 5 of this manual or contact Bonitron for assistance.

5. MAINTENANCE AND TROUBLESHOOTING

Repairs or modifications to this equipment are to be performed by Bonitron approved personnel only. Any repair or modification to this equipment by personnel not approved by Bonitron will void any remaining warranty on this unit.

5.1. PERIODIC TESTING

At least every other month, visually inspect the front panel indicator lights to be sure they are operating correctly. The green **DC Bus** indicator will be on if the drive bus is above 40VDC. The red **Active Braking** indicator will only be on or flashing if the module is absorbing energy from the DC Bus. There are no operational tests to be performed.

5.2. MAINTENANCE ITEMS

Monthly, check the module for buildup of dust, debris, or moisture. Dangerous voltages exist within the module and the buildup of dust, debris, and moisture can contribute to unwanted arcing and equipment damage. Keep the module clean and moisture free.

Monthly, check the cooling fan and heatsink for any buildup of debris. If they require cleaning, **power down the drive system** and blow the debris out with clean dry air to maintain proper cooling performance. **Note:** After blowing out the fan and/or heatsink, blow off any dust or debris that may have gotten on any of the circuit boards.

5.3. TROUBLESHOOTING



Lethal voltages exist in these systems! Before attempting checks or repair, follow all precautions to ensure safe working conditions, including lockout/tagout procedures, and verifying safe working voltages with proper meters. Do not rely on the DC Bus indicator to ensure a safe condition!



Only qualified personnel familiar with adjustable frequency AC drives and associated machinery should plan or implement the installation, start-up, and subsequent maintenance of the system. Failure to comply may result in personal injury, death, and/or equipment damage!

Feel free to call Bonitron any time the equipment appears to be having problems.

5.3.1. DC BUS LIGHT NOT ILLUMINATED

This can be a normal condition in systems where DC bus power and logic control power is applied. This indicates that there is less than 40VDC on the inverter bus.



Do not use this light as an indication that the DC bus is safe to work on! Always check the DC bus with a working voltmeter before servicing equipment, as the DC bus light may be broken!

- Use a DC voltmeter to check the DC bus voltage at the module terminals DC Bus + and DC Bus —.
- If the DC bus is above 40VDC, and the light is not illuminated, the light or control circuit may be damaged, and the unit should be returned for repair.
- The main DC bus fuse may be blown. See below.

5.3.2. BLOWN DC BUS FUSE



Do NOT replace a blown DC bus fuse and reapply power to the system without determining the cause!

This usually indicates serious problems exist and reenergizing the system can cause significant or catastrophic failure! In most cases, the module will need to be returned for repair. Contact Bonitron before changing the fuse.

Possible causes for a blown fuse are:

- Shorted heatsink IGBT power transistor.
- Shorted heatsink commutation diode.
- Load bank in use below minimum ohms value.
- Shorted load bank.
- Shorted resistor cabling and or ground fault in cable.
- Operating braking module on a DC bus without inverters present. This is typically encountered in common bus systems when drives are removed from service. See Section 7 for more information.

5.3.3. FAN RUNS CONSTANTLY

The fan only runs when the braking module is actively braking. Once active braking as stopped, the fan will run for an additional four minutes. If you have braking events within four minutes of each other, the fan will run continuously. If the fan is still running after the unit has sat idle for a while, the control board may be faulty. Contact Bonitron for return for repair.

5.3.4. FAN DOESN'T RUN

The fan only runs when the braking module heatsink is hot. If the heatsink is above 110°F, then the fan runs until the heatsink cools to 80°F.

If the fan never runs, even when the heatsink is hot or during heavy braking operation, the module may shutdown on heatsink over-temperature. This occurs at a heatsink temperature of 160°F. If for any reason the fan does not appear to be working properly, check the following:

- Check fan for blockage. Clean if necessary.
- Replace fan.
- If fan still doesn't operate, the control board may be faulty. Contact Bonitron for return for repair.

5.3.5. CONTROL READY CONTACTS WON'T CLOSE

If the Status Contacts listed in Section 4.2.2.1 above will not close, this indicates one of the following conditions:

- Open Load – There is no load connected to the unit, or it is connected improperly.
- Overtemperature – see below.
- Damaged IGBT – IGBT has failed, and must be returned for repair.

5.3.6. MODULE OVER-TEMP, OR MODULE SEEMS TOO HOT

It is normal for this module to produce heat. Temperatures of 150°F are not uncommon. If the module fan is running, and the module is operating properly, it is within normal tolerances.

If the fan is not running, see Section 5.3.4 above for assistance.

If the fan is running, check to make sure the airflow through and around the module is unobstructed.

If the ambient temperature is high in the cabinet or installation area, the module may overheat. Make sure the environment is within the operating temperature requirements listed in the general specifications in Table 2-3.

5.3.7. DRIVE TRIPS ON OVERVOLTAGE

Make sure the DC+ and DC- connections are made directly to the drive system bus. They should not be connected to terminals dedicated to an internal transistor circuit, on the inverter.

If the drive trips on overvoltage and the module is ready to operate, watch the Active Braking light on the front of the module. If it never illuminates, check the connections to the DC bus of the drive system. Check the DC bus voltage and make sure the bus voltage at the braking module exceeds the trip point of the module, i.e. 750VDC for a 460VAC nominal system. (See Table 2-1) If the Active Braking light comes on, check the wiring to the load bank, and check the current to the load bank with a clamp on current meter. If the wiring to the load bank is good, make sure the DC bus fuse is good, if installed.

If the "Active Braking" light comes on, and current is flowing to the load bank, check to make sure that the module is sized properly for the system. If the resistance of the load bank is too high, not enough current will flow to allow for the braking energy to be dissipated. Check the system design to make sure the braking requirements are matched with the braking module capacity.

5.3.8. BRAKING LIGHT FLICKERS

During motor deceleration, the braking LED may flicker if the braking cycle energy is low. This is normal.

If the braking light flickers when the inverter is idle, this may indicate high voltage, excessive noise, or harmonics on the main system rectifier input AC voltage. Check the incoming AC line for these problems. Consult the project engineer for the appropriate corrective action.

In rare instances, the module is installed on a system that has very little capacitance, or the inverters have been removed from the bus. This configuration can cause damage to the braking module. See Section 7.1 for more information.

5.3.9. ACTIVE BRAKING LIGHT STAYS ON ALL THE TIME

- System voltage is too high or high harmonic content is present. Check main system rectifier input AC voltage. Refer to the DC bus trigger level found in Table 2-1. The undistorted main system rectifier AC input voltage should always be less than DC bus trigger level / 1.414.
 - Note: If the measured DC bus (in standby) is greater than the RMS line voltage*1.414, then harmonic distortion may exist. Consult the project engineer for the appropriate corrective action.
- Setpoint too low. The DC bus setpoint pot on the main control board may have been tampered with. If this is a possibility, then the module needs to be sent in for recalibration.
- Wrong braking module installed. Check the module chassis sticker for the part number. Refer to Section 2.2 of this manual and verify that the sticker information represents the correct part number for your application and voltage levels. Remove and replace as required.
- Main control board has gone bad. Module needs to be sent in for repair.

5.3.10. ATTACHED DRIVE WILL NOT PRECHARGE

- Verify the polarity of the connection to the DC filter capacitors of the drive. If this connection is reversed, the commutation diode effectively shorts the DC bus and will not allow the drive to go through precharge.

5.4. TECHNICAL HELP – BEFORE YOU CALL

If possible, please have the following information when calling for technical help:

- Model number of unit
- Serial number of unit
- Name of original equipment supplier
- Brief description of the application
- Drive and motor hp or kW
- The line to line voltage on all 3 phases
- The DC bus voltage
- kVA rating of power source
- Source configuration Wye/Delta and grounding

6. ENGINEERING DATA

6.1. RATINGS CHARTS

Table 6-1: Module Ratings

MODEL NUMBER	DRIVE VOLTAGE	I _{PK}	I _{RMS}	DUTY CYCLE	MAX BRAKING POWER	MIN LOAD Ω	CHASSIS SIZE
M3575T-L15	230VAC	15A	3.87A	20%	8HP	25.00Ω	M3
M3575T-L30		30A	7.75A	20%	15HP	12.50Ω	M3
M3575T-L60		60A	15.5A	20%	30HP	6.25Ω	M4
M3575T-L150		150A	38.73A	20%	75HP	2.50Ω	B5
M3575T-L200		200A	51.64A	20%	100HP	1.90Ω	B7
M3575T-L300		300A	77.46A	20%	150HP	1.30Ω	B7
M3575T-L600		600A	154.92A	20%	300HP	0.70Ω	B7
M3575T-E15	400VAC	15A	3.87A	20%	12.5HP	41.25Ω	M3
M3575T-E30		30A	7.75A	20%	25HP	20.50Ω	M3
M3575T-E75		75A	19.36A	20%	63HP	8.25Ω	M4
M3575T-E150		150A	38.73A	20%	125HP	4.10Ω	B5
M3575T-E200		200A	51.64A	20%	165HP	3.10Ω	B7
M3575T-E300		300A	77.46A	20%	250HP	2.00Ω	B7
M3575T-E600		600A	154.92A	20%	500HP	1.03Ω	B7
M3575T-H15	460VAC	15A	3.87A	20%	15HP	50.00Ω	M3
M3575T-H30		30A	7.75A	20%	30HP	25.00Ω	M3
M3575T-H75		75A	19.36A	20%	75HP	10.00Ω	M4
M3575T-H150		150A	38.73A	20%	150HP	5.00Ω	B5
M3575T-H200		200A	51.64A	20%	200HP	3.75Ω	B7
M3575T-H300		300A	77.46A	20%	300HP	2.50Ω	B7
M3575T-H600		600A	154.92A	20%	600HP	1.25Ω	B7

6.2. WATT LOSS

Ratings assume losses during highest braking currents. Total heat produced will depend on the duty cycle of the braking function.

Table 6-2: Watt Loss

230VAC

MODEL NUMBER	CONTROL POWER WATT LOSS	HEATSINK WATT LOSS
M3575T-L15	25 W	20 W
M3575T-L30	25 W	35 W
M3575T-L60	25 W	75 W
M3575T-L125	25 W	75 W
M3575T-L150	25 W	100 W
M3575T-L200	25 W	120 W
M3575T-L300	25 W	150 W
M3575T-L600	25 W	300 W

400VAC

MODEL NUMBER	CONTROL POWER WATT LOSS	HEATSINK WATT LOSS
M3575T-E15	25 W	10 W
M3575T-E30	25 W	20 W
M3575T-E75	25 W	45 W
M3575T-E125	25 W	75 W
M3575T-E150	25 W	100 W
M3575T-E200	25 W	120 W
M3575T-E300	25 W	150 W
M3575T-E600	25 W	300 W

460VAC

MODEL NUMBER	CONTROL POWER WATT LOSS	HEATSINK WATT LOSS
M3575T-H15	25 W	10 W
M3575T-H30	25 W	20 W
M3575T-H75	25 W	45 W
M3575T-H125	25 W	75 W
M3575T-H150	25 W	100 W
M3575T-H200	25 W	120 W
M3575T-H300	25 W	150 W
M3575T-H600	25 W	300 W

6.3. CERTIFICATIONS

Units rated up to and including 75 Amps peak are UL approved. Refer to UL file number E204386.

6.4. UL 508A SHORT CIRCUIT CURRENT RATING

When braking transistors are used with Underwriters Laboratories listed or recognized drives, the short circuit current rating (SCCR) is determined by the SCCR rating of the attached drive.

6.5. FUSE SIZING AND RATING

Some installations may require fuses to be placed in the DC link of the braking system. In these cases, refer to the following semiconductor fuse current rating charts. Breakers are not recommended for overcurrent protection.

Table 6-3: Semiconductor Fuse Current Rating Requirements

230VAC		400VAC	
MODEL NUMBER	FUSE RATING (SEMICONDUCTOR TYPE)	MODEL NUMBER	FUSE RATING (SEMICONDUCTOR TYPE)
M3575T-L15	10A	M3575T-E15	10A
M3575T-L30	20A	M3575T-E30	20A
M3575T-L60	40A	M3575T-E75	40A
M3575T-L125	70A	M3575T-E125	70A
M3575T-L150	80A	M3575T-E150	80A
M3575T-L200	100A	M3575T-E200	100A
M3575T-L300	150A	M3575T-E300	150A
M3575T-L600	200A	M3575T-E600	200A

460VAC

MODEL NUMBER	FUSE RATING (SEMICONDUCTOR TYPE)
M3575T-H15	10A
M3575T-H30	20A
M3575T-H75	40A
M3575T-H125	70A
M3575T-H150	80A
M3575T-H200	100A
M3575T-H300	150A
M3575T-H600	200A

6.6. DC BUS LENGTH LIMITS

The distance that the chopper is mounted from the main DC bus filter capacitors within the drive is limited by the amount of inductance in the connection. During switching, the inductance in the DC bus between the chopper and capacitors stores energy that must be absorbed by the snubbing circuit in the chopper.

The values listed in Table 6-4 are the maximum inductance allowed in the DC bus link to and from the filter capacitors in the drive and the chopper connections.

The separation distance between the two can be increased by using low inductance buswork or cables, typically this means using buswork or cable with a higher cross-sectional area. The inductance of the buswork can be calculated from the length and inductance/foot published by the cable manufacturer. There are also standard tables to help this calculation.

Table 6-4: Maximum Inductance for DC Link Cable

MODEL	AMPERAGE	MAXIMUM INDUCTANCE
3575T-x15	15 A	1000uH
3575T-x30	30 A	650uH
3575T-x60	60 A	350uH
3575T-x75	75 A	350uH
3575T-x125	125 A	750uH
3575T-x150	150 A	750uH
3575T-x200	200 A	620uH
3575T-x300	300 A	275uH
3575T-x600	600 A	70uH

6.7. DIMENSIONS AND MECHANICAL DRAWINGS

Figure 6-1: M3 Chassis Dimensional Outline Drawing

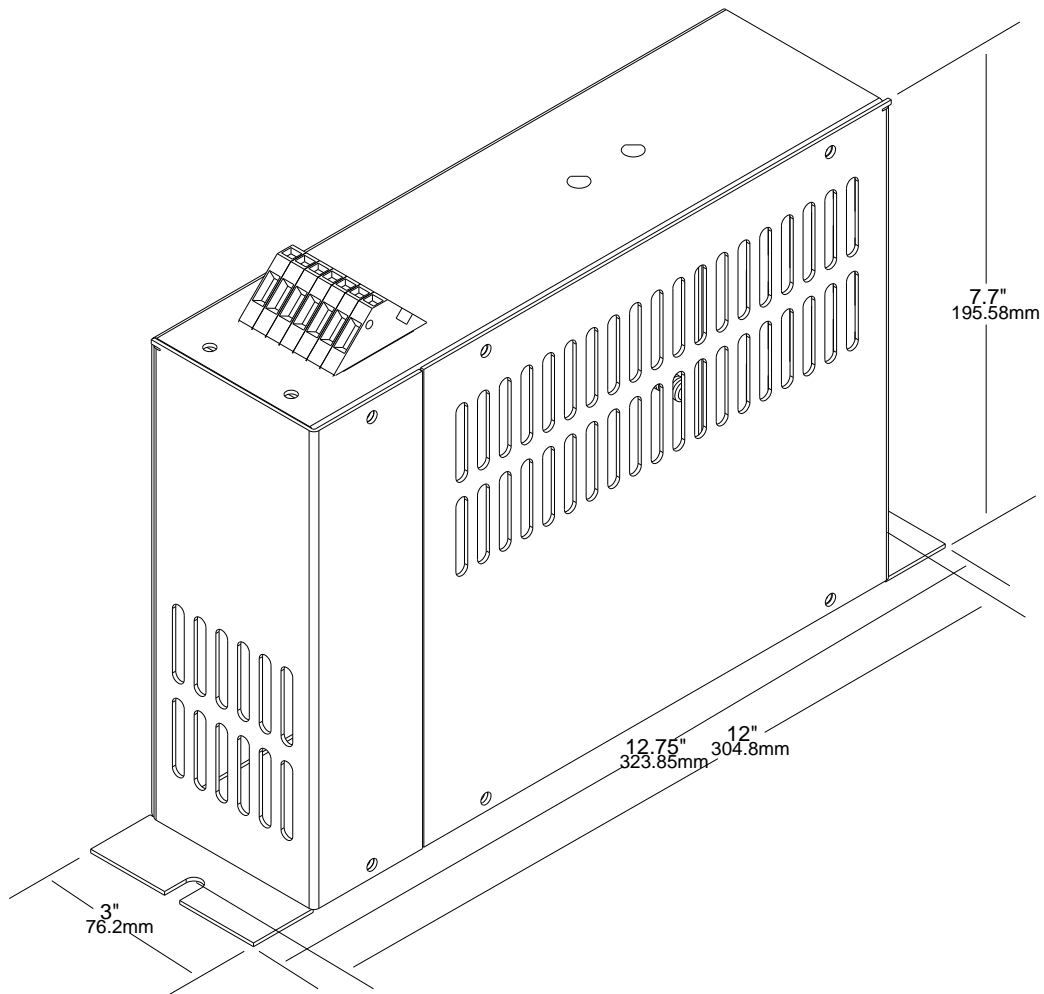

Figure 6-2: M4 Chassis Dimensional Outline Drawing

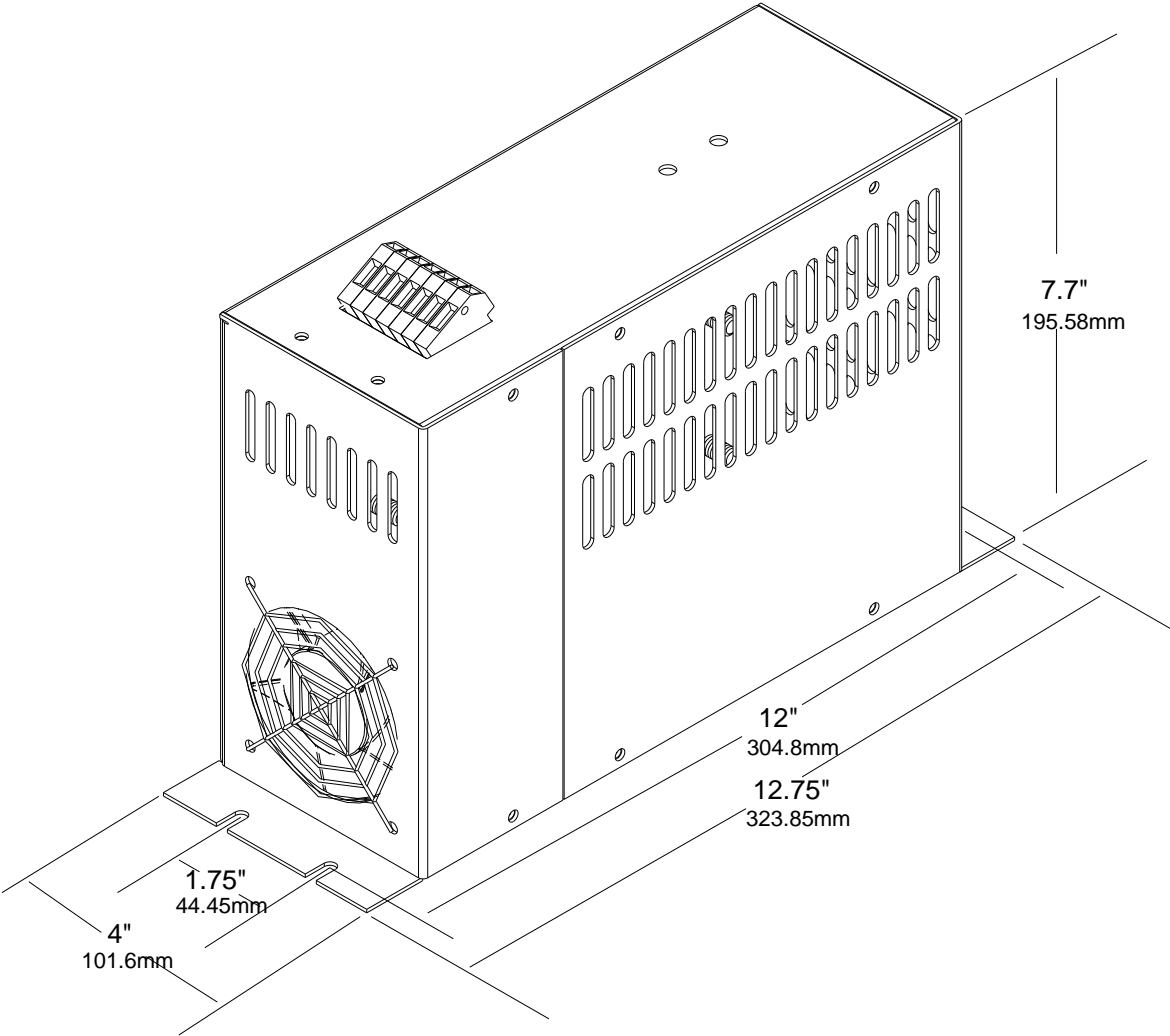

Figure 6-3: B5 Chassis Dimensional Outline Drawing

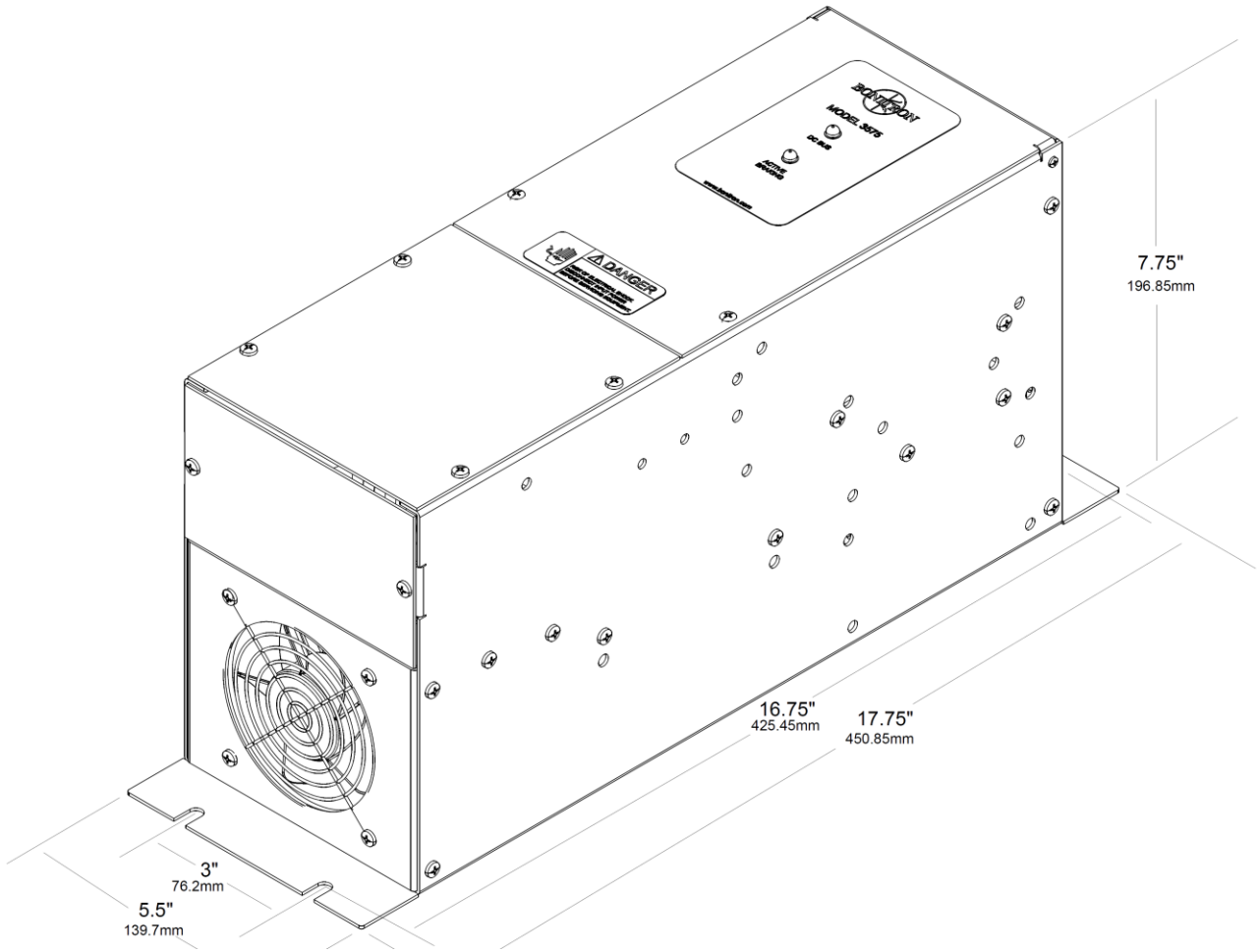

Figure 6-4: B7 Chassis Dimensional Outline Drawing

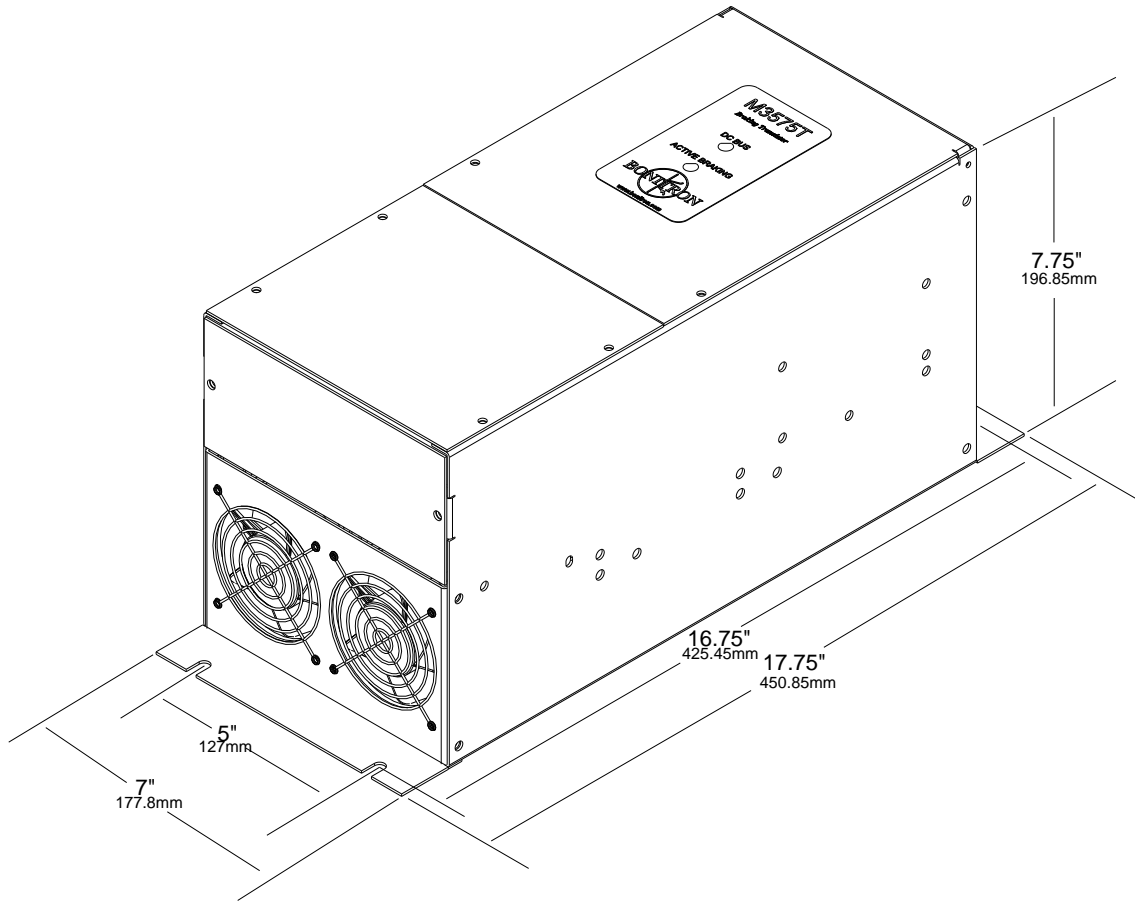

Figure 6-5: MTW 3575-CVR-30U Conduit Cover Dimensional Outline

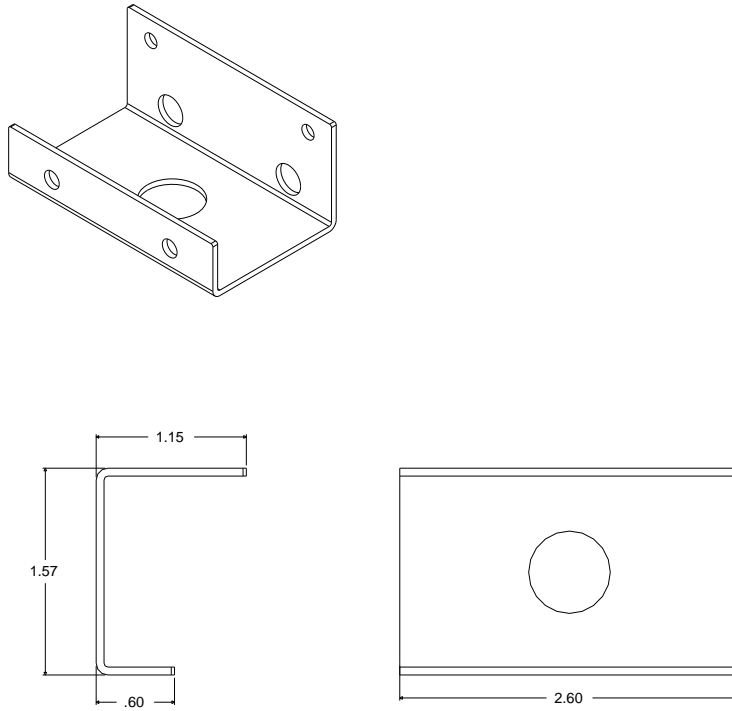
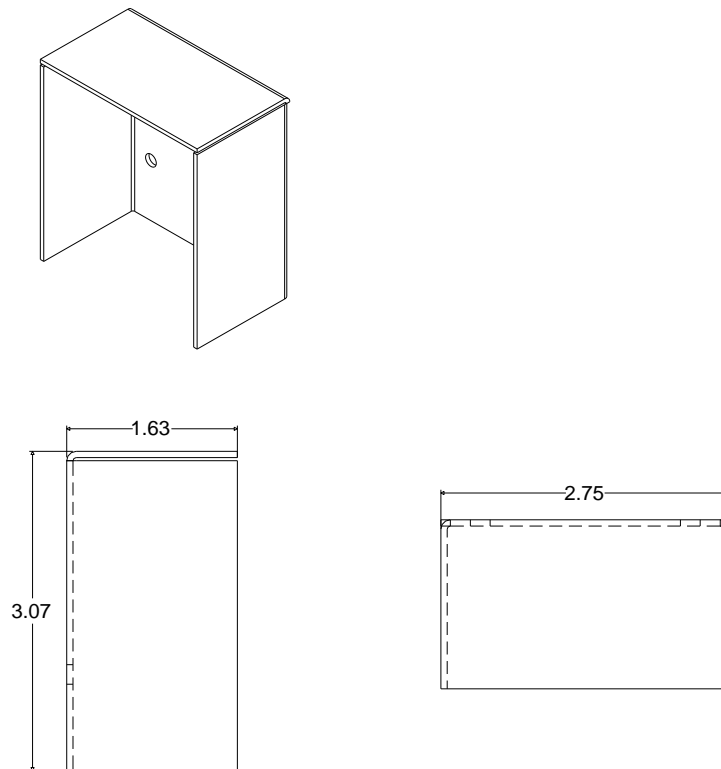
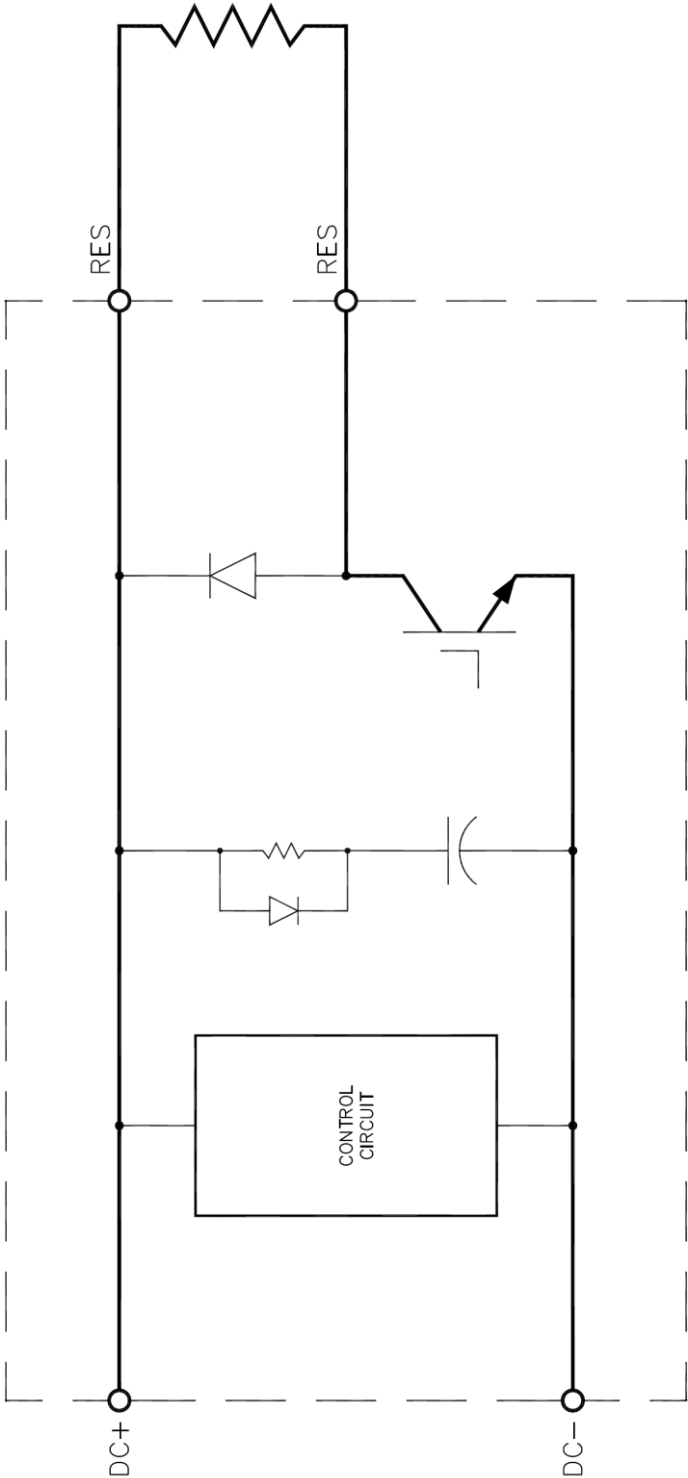

Figure 6-6: MTW 3575-CVR-30 Conduit Cover Dimensional Outline



6.8. BLOCK DIAGRAM

Figure 6-7: Block Diagram



7. APPENDIX

7.1. APPLICATION NOTES

7.1.1. SIZING YOUR BRAKING REQUIREMENTS

Braking transistor modules are sized by peak current requirements and system voltage. Please use the following guidelines:

- Verify the amount of peak power needed for braking. This must be determined from the mechanical system layout, and should be calculated in either peak watts or horsepower.
- VFD's are rated for braking power as well as peak braking capacity. This information is available in the drive manual. This will be the maximum amount of power that the output inverter stage of the VFD can absorb from the load before having an overcurrent condition. Refer to your VFD documents for information on drive sizing. Keep in mind that the current rating of the drive is for three phase current, not DC bus current. The braking current in the DC bus will be higher than the AC current absorbed from the load.
- Because Bonitron braking transistor modules are rated for peak current, determine the *peak* braking power required.

7.1.1.1. HORSEPOWER TO WATTS

Once the braking requirements for the mechanical load are determined, multiply the horsepower by the scaling factor of 746 W/hp to determine the wattage required. For instance, with a 400hp system, the peak braking power may be 600hp. In this case the peak power required would be:

$$P_{brake} = hp \cdot Braking * 746 \quad P_{brake} = 600hp * 746 = 447600 \text{ watts}$$

7.1.1.2. PEAK AMPERAGE

The peak amperage of the braking cycle can be determined by dividing the peak braking wattage by the system bus trip point of the braking transistor module used. If the above example were on a 480VAC system, the trip point is 750VDC, as determined from Table 2-1. In this case the peak current required would be:

$$I_{brake} = P_{braking} / 750VDC \quad I_{brake} = 447600 \text{ watts} / 750VDC = 596.8ADC$$

In this case, a 600 amp module should be used.

7.1.1.3. OHMIC VALUE

The ohmic value of the resistive load can usually be determined from the module ratings (see Table 6-1). This ohmic value indicates the capacity of the braking transistor module, and may not be directly related to the horsepower of the drive. To calculate the required ohmic value for the braking load, use the following formula:

$$R_{brake} = \frac{(V_{DCbus})^2}{P_{brake}}$$

The DC bus voltage for the equation is determined by the level that the drive begins braking. For 460/480VAC systems, this is typically 750VDC, for 230VAC systems, it is typically 375VDC. Refer to your drive manual for specifics.

For the above example, the ohmic value would be:

$$R_{brake} = (750VDC)^2 / 447600 \text{ watts} = 1.26 \text{ ohms}$$

This value must be verified with the ratings of the braking transistor module selected that it is not less than the “minimum ohmic value” for that model. If so, the braking requirements may be more than the braking transistor module can absorb, and a larger module may be required.

If the ohmic value calculated is greater than the value listed in the ratings table, it is possible to select a resistor value lower than the calculated value.

7.1.1.4. DUTY CYCLE

The duty cycle is based on the amount of time the drive is actually braking as opposed to accelerating, running at constant speed, or idle. For instance, if a pick and place operation requires 3 seconds to accelerate, traverses for 44 seconds and then decelerates for 3 seconds, the total cycle time is:

$$T_{cycle} = T_{acc} + T_{run} + T_{dec} = 3 + 44 + 3 = 50 \text{ sec}$$

The duty cycle for braking is:

$$\%_{duty} = T_{dec} / T_{cycle} = .06 = 6\%$$

This rating assumes the load will be linearly decreasing from peak braking power to zero braking as the load comes to a stop.

Check this rating against the modules duty cycle rating, and if it is higher than rated, go to the next higher rated module. If a duty cycle is required over 50%, please call for assistance with your application.

7.1.1.5. CONTINUOUS RATING

The continuous rating is listed for long term heating calculations should the unit be installed in an area where heat dissipation is an issue. The rating is based on a triangular cycle that starts at peak value and reduces to zero within the rated duty cycle. Therefore, the average braking power during the deceleration cycle is ½ the power required if full power was required during the entire braking cycle. This value is:

$$P_{continuous} = P_{peak} * \%_{duty} / 2$$

For the above example, the

$$P_{continuous} = 447600W * 6\% / 2 = 13428 W$$

7.1.2. STATUS CONTACT CONNECTION NOTES

The model M3575R series of resistive load modules are available in a variety of load sizes and configurations for use with the M3575T braking transistor modules or with the drive’s integral braking control module. Contact your drive distributor for more information.

This section provides possible schemes for the field connection of the status contact outputs provided in the M3575T and M3575R resistive braking modules. The connection schemes showed in Figures 7-1 and 7-2 give two possibilities for utilizing the status contacts that are provided with these modules. Please refer to the drive system documentation for field control interlock connection details. Actual connection points and terminal numbers

for the AC drive module should be found in the documentation provided with the drive. Be sure to review all pertinent drive and system documentation as well as the status connection notes in Table 3-2 before proceeding.

The connection diagrams shown below assume the use of the model M3575R resistive load module. The actual load module used may vary. Refer to the drive system documentation for details on the actual load module used.



*Please note that the status contact within the M3575T remains **CLOSED** until a fault condition occurs. Fault conditions include Open Load, Over Temperature, and Transistor Failure.*

Figure 7-1: Typical Status Contact Wiring with Input Contactor

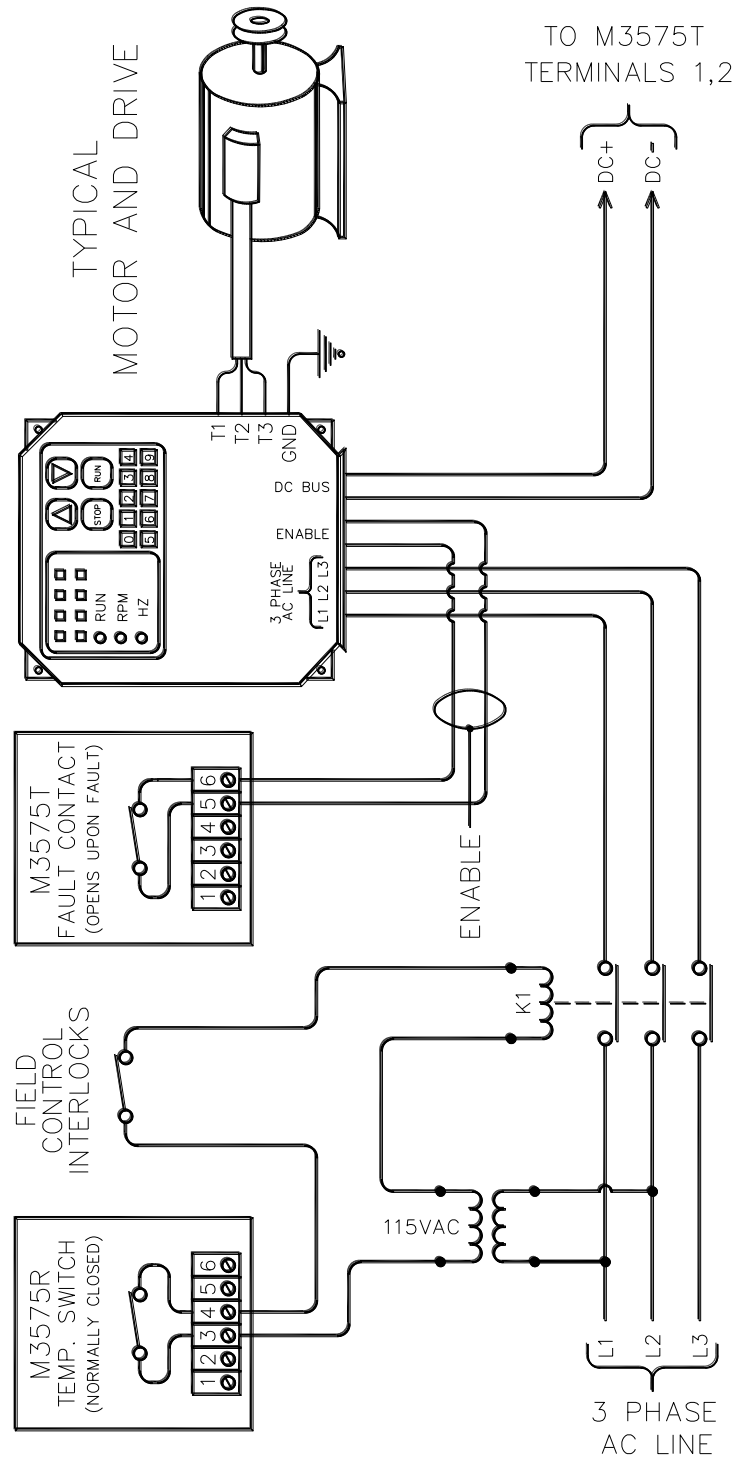
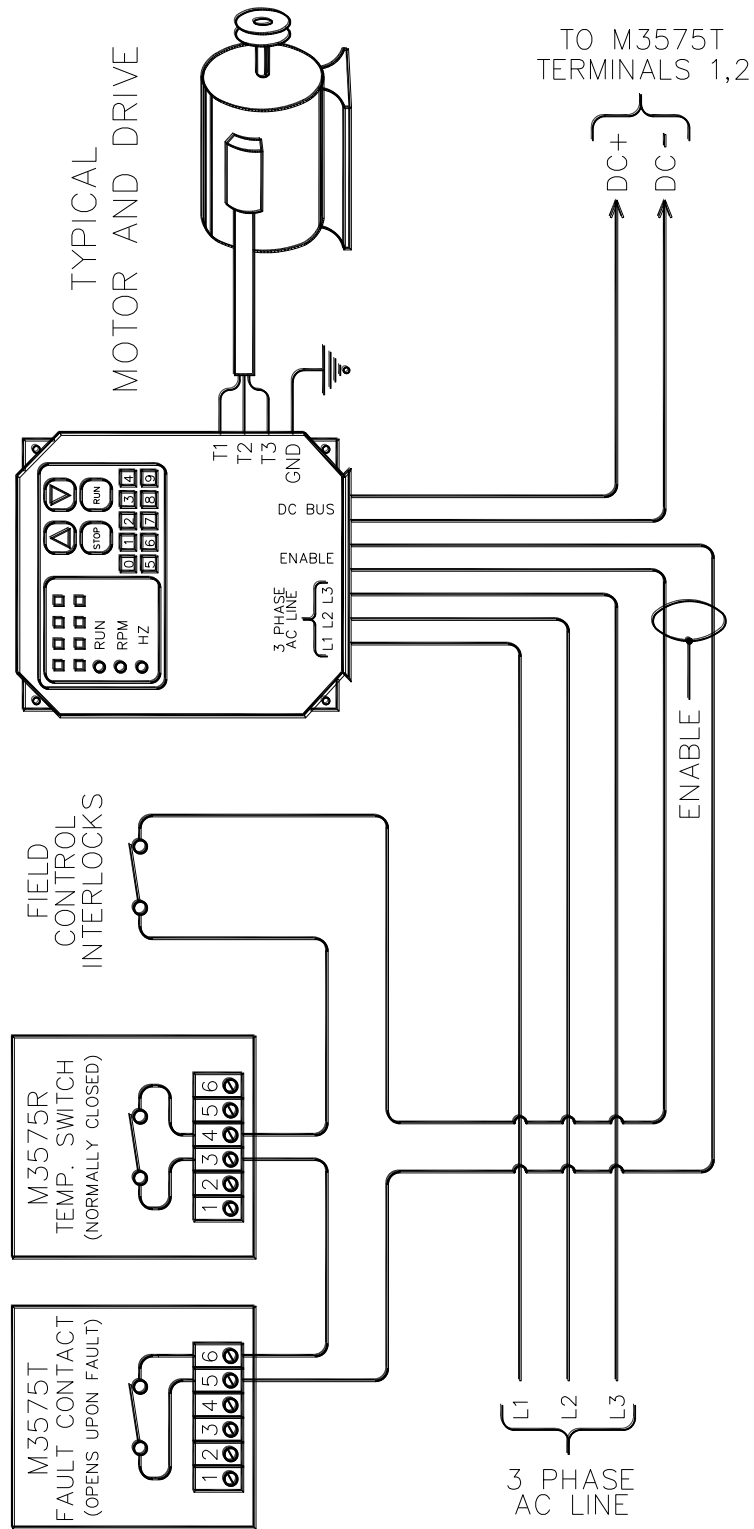

Figure 7-2: Typical Status Contact Wiring with Drive Interlock Control



7.1.3. COMMON BUS NOTES

Bonitron dynamic braking transistor modules are designed to be compatible with individual stand-alone inverter/drive systems, or systems that incorporate a common DC bus arrangement. The common DC bus can be composed of multiple inverter/drive sections tied together where all or some of the sections use their respective AC input, or there may be a large independent master DC bus supply feeding the DC inputs of all inverter/ drive sections. In the case of the large master DC Bus supply, it is common to find multiple rectifier sections in parallel to provide very high power levels. Some high power systems also include redundant or back up sections as well.

Once power is applied, all Bonitron modules are designed to be connected to DC buses that have all the bus capacitors present.

Common DC bus systems composed of separate master DC bus or rectifier sections have important imbedded differences. It is common to have a main distributed DC bus, and this is typically where the dynamic braking transistor modules connect. In this way, the dynamic braking system is always present, even if some of the inverter/drive sections need to be removed from the bus for maintenance or other purposes. In emergency situations, it may even be necessary to “limp” along until repairs or swap outs can occur. Even though the modules are well suited for use in these systems, the following modes of operation could arise or exist and **are not allowed**:

1. **Do not** connect the dynamic braking transistor module on the rectifier side of a DC link choke. The connections must always be made to the inverter/drive side directly to the DC bus capacitors. During normal system operation, the choke can cause the braking system to begin ringing. This ringing causes high voltages that will damage the system.
2. **Do not** energize the system with no inverters/drives present on the distributed DC bus.
3. **Do not** energize, operate, or run the system with less than 60% of the total expected system capacitance present.
4. Operating the modules in conditions 2 and 3 may make the modules respond to inbound line transients caused by SCR type rectifiers, powering up the system, or any number of other sources. Without sufficient DC bus capacitance, the DC bus will not be filtered, and can cause ringing that will produce high voltages that will damage the system
5. In some drives, the pre-charge contactor may open under fault conditions, leaving the bulk system capacitance only resistively coupled to the braking transistor modules. **Do not** use the modules in this situation. Review inverter/drive DC bus pre-charge circuit operation with the drive manufacturer.

Always consult Bonitron with any questions or concerns surrounding this topic.

NOTES

This page is intentionally left blank

This page is intentionally left blank.

