



Solutions for AC Drives

Model M3545P
Regenerative
DC Bus Power Supply

Customer Reference Manual

Bonitron, Inc.
Nashville, TN



An industry leader in providing solutions for AC drives.

ABOUT BONITRON

Bonitron designs and manufactures quality industrial electronics that improve the reliability of processes and variable frequency drives worldwide. With products in numerous industries, and an educated and experienced team of engineers, Bonitron has seen thousands of products engineered since 1962 and welcomes custom applications.

With engineering, production, and testing all in the same facility, Bonitron is able to ensure its products are of the utmost quality and ready to be applied to your application.

The Bonitron engineering team has the background and expertise necessary to design, develop, and manufacture the quality industrial electronic systems demanded in today's market. A strong academic background supported by continuing education is complemented by many years of hands-on field experience. A clear advantage Bonitron has over many competitors is combined on-site engineering labs and manufacturing facilities, which allows the engineering team to have immediate access to testing and manufacturing. This not only saves time during prototype development, but also is essential to providing only the highest quality products.

The sales and marketing teams work closely with engineering to provide up-to-date information and provide remarkable customer support to make sure you receive the best solution for your application. Thanks to this combination of quality products and superior customer support, Bonitron has products installed in critical applications worldwide.

AC DRIVE OPTIONS

In 1975, Bonitron began working with AC inverter drive specialists at synthetic fiber plants to develop speed control systems that could be interfaced with their plant process computers. Ever since, Bonitron has developed AC drive options that solve application issues associated with modern AC variable frequency drives and aid in reducing drive faults. Below is a sampling of Bonitron's current product offering.

WORLD CLASS PRODUCTS

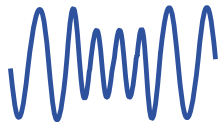

Undervoltage Solutions

Uninterruptible Power for Drives
(DC Bus Ride-Thru)
Voltage Regulators
Chargers and Dischargers
Energy Storage

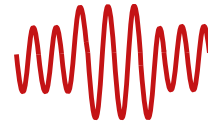

Overvoltage Solutions

Braking Transistors
Braking Resistors
Transistor/Resistor Combo
Line Regeneration
Dynamic Braking for Servo Drives



Common Bus Solutions

Single Phase Power Supplies
3-Phase Power Supplies
Common Bus Diodes



Portable Maintenance Solutions

Capacitor Formers
Capacitor Testers

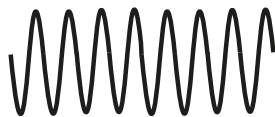

Power Quality Solutions

12 and 18 Pulse Kits



Green Solutions

Line Regeneration

1. INTRODUCTION.....	7
1.1. Who should use	7
1.2. Purpose and Scope.....	7
1.3. Manual version and change record.....	7
Figure 1-1: Typical M3545P Regenerative Power Supply.....	7
1.4. Symbol Conventions Used in this Manual and on Equipment.....	8
2. PRODUCT DESCRIPTION.....	9
2.1. Related Products	9
2.2. Part Number Breakdown	9
Figure 2-1: Example of M3545P Part Number Breakdown.....	9
Table 2-1: Voltage Ratings	10
Table 2-2: Chassis Styles	10
Table 2-3: Option Codes	10
2.3. General Specifications Chart.....	11
Table 2-4: General Specifications.....	11
2.4. General Precautions and Safety Warnings	12
3. INSTALLATION INSTRUCTIONS.....	13
3.1. Environment	13
3.2. Unpacking.....	13
3.3. Mounting	13
Figure 3-1: M3545P Mounting Orientation	14
3.4. Wiring and Customer Connections.....	15
3.4.1. Power Wiring.....	15
Table 3-1: Power Terminal Specifications.....	16
Figure 3-1: 6 Amp M3545P Power & I/O Connection Location	16
Figure 3-2: 15 Amp M3545P Power & I/O Connection Location	17
3.4.2. I/O Wiring.....	17
Table 3-2: M3545P 6 Amp I/O Wiring.....	17
Table 3-3: M3545P 15 Amp I/O Wiring	17
Figure 3-3: 6 Amp M3545P I/O Diagram	18
Figure 3-4: 15 Amp M3545P I/O Diagram	18
3.5. Typical Configurations.....	19
Figure 3-5: M3545P Power Wiring.....	20
Figure 3-6: M3545P Multiple Drives Field Wiring Diagram.....	21
OPERATION.....	22
3.6. Functional Description	22
3.7. Features.....	22
3.7.1. Indicator LEDs.....	22
3.8. Faults	22
3.8.1. Operational Faults.....	22
Table 3-4: Blink Codes	22
3.8.2. System Faults	23
Table 3-5: System Faults.....	23
3.9. User I/O Connections	23
Table 3-6: M3545 6A User I/O Terminals.....	23
Table 3-7: M3545 15A User I/O Terminals.....	24
3.10. Startup.....	24
3.10.1. Pre-power Checks	24
3.10.2. Startup Procedure and Checks	24

Table of Contents

3.10.3. Cooling Fan.....	24
4. MAINTENANCE AND TROUBLESHOOTING.....	26
4.1. Periodic Testing.....	26
4.2. Maintenance Items.....	26
4.3. Troubleshooting.....	26
4.3.1. POWER LED is not on.....	26
4.3.2. READY output will not close.....	26
4.3.3. Over Voltage fault on Drive or Regen.....	26
4.3.4. Overtemperature Fault.....	27
4.3.5. IGBT Desat Fault.....	27
4.3.6. Phase Loss Fault.....	27
4.3.7. Fuses fail on power on.....	27
4.4. Technical Help – Before you contact us.....	27
5. ENGINEERING DATA.....	28
5.1. Ratings Charts.....	28
Table 5-1: Ratings and Specifications – 230 - 240VAC.....	28
Table 5-2: Ratings and Specifications – 460 - 480VAC.....	28
5.2. Derating Parallel M3545P.....	28
Table 5-3: Derating M3545P in Parallel.....	28
5.3. Watt Loss.....	29
5.4. Certifications.....	29
5.4.1. UL 61800-5-1.....	29
5.4.2. RoHS.....	29
5.5. Fuse Selection.....	29
Table 5-4: Fuse Current Rating Requirements.....	29
5.6. Dimensions and Mechanical Drawings.....	30
Figure 6 1: M3545P – 6 Amps C4 Chassis Dimensional Outline.....	30
Figure 6 2: M3545P – 6 Amps A4 (Obsolete) Chassis Dimensional Outline.....	31
Figure 5-1: M3545P M4 Chassis Dimensional Outline.....	32
6. APPENDIX.....	33
6.1. Application Notes.....	33
6.1.1. Sizing the M3545P.....	33
6.1.2. Calculating Energy Savings.....	34

This page intentionally left blank

1. INTRODUCTION

1.1. WHO SHOULD USE

This manual is intended for use by anyone who is responsible for integrating, installing, maintaining, troubleshooting, or using this equipment with any AC Drive System. Please keep this manual for future reference.

1.2. PURPOSE AND SCOPE

This manual is a user's guide for the Model M3545P regenerative power supply. It provides you with the necessary information to successfully install and use the M3545P unit in your application.

In the event of any conflict between this document and any publication and/or documentation related to the application, the latter shall have precedence.

1.3. MANUAL VERSION AND CHANGE RECORD

The initial release of the M3545P Line Regen is Rev 00a.

Fuse current ratings and recommended fuses Table 6-4 was updated in Rev 0b.

Updated table 7.1.1 in Rev 00c.

Updated table 6-4 in Rev 00d.

Added 6 Amp M3645P to manual in rev00e.







Obsoleting A4 chassis and adding C4 chassis in Rev02a.

Updated voltage (and power) ratings in tables 2-1, 2-4, 6-1, and 6-3.

Figure 1-1: Typical M3545P Regenerative Power Supply



1.4. SYMBOL CONVENTIONS USED IN THIS MANUAL AND ON EQUIPMENT

	<p>Earth Ground or Protective Earth</p>
	<p>AC Voltage</p>
	<p>DC Voltage</p>
 <p>DANGER!</p>	<p>DANGER: Electrical hazard - Identifies a statement that indicates a shock or electrocution hazard that must be avoided.</p>
 <p>DANGER!</p>	<p>DANGER: Identifies information about practices or circumstances that can lead to personal injury or death, property damage, or economic loss.</p>
 <p>CAUTION!</p>	<p>CAUTION: Identifies information about practices or circumstances that can lead to property damage, or economic loss. Attentions help you identify a potential hazard, avoid a hazard, and recognize the consequences.</p>
 <p>CAUTION!</p>	<p>CAUTION: Heat or burn hazard - Identifies a statement regarding heat production or a burn hazard that should be avoided.</p>

2. PRODUCT DESCRIPTION

The M3545P Regenerative DC Power Supply is a bi-directional power supply. During normal operation it sources energy to the drive through the DC bus. If the DC bus voltage begins to rise, due to the drive trying to brake or an overhauling load, the M3545P will sink energy back to the AC Line. Under motoring conditions, the M3545P rectifies the AC line and supplies power to the drive through its DC bus terminals.

Alternative resistive braking solutions simply dissipate this regenerated energy as heat. Bonitron's M3545P returns the regenerated energy back to the AC line, making it particularly well suited for applications with frequent or extended duration braking events.

Additionally, the M3545P is designed to be able to operate on both single-phase and three-phase AC grids, at either 50Hz or 60Hz line frequency.

2.1. RELATED PRODUCTS

COMMON BUS DIODES

- M3345CBM Sharing Diode

BRAKING RESISTORS

- M3575R Standard Duty Braking Resistors (<30A)
- M3775R Various Duty Load Banks (<1600A)

BRAKING TRANSISTORS

- M3452 Heavy Duty Braking Transistor (<1600A)
- M3575T Standard Duty Braking Transistor (<600A)
- M3675T Low HP Braking Transistor (<10A)

THREE PHASE POWER SUPPLIES

- M3713DM Non-Regenerative Power Supply (<375A)
- M3713SC Non-Regenerative Power Supply with Precharge (<375A)

LINE REGEN

- M3545 Single Phase or Three Phase Line Regen (<15A)
- M3645 Heavy Duty Line Regen (<375A)

RESISTIVE PRECHARGE

- M3728 Precharge Module

2.2. PART NUMBER BREAKDOWN

Figure 2-1: Example of M3545P Part Number Breakdown

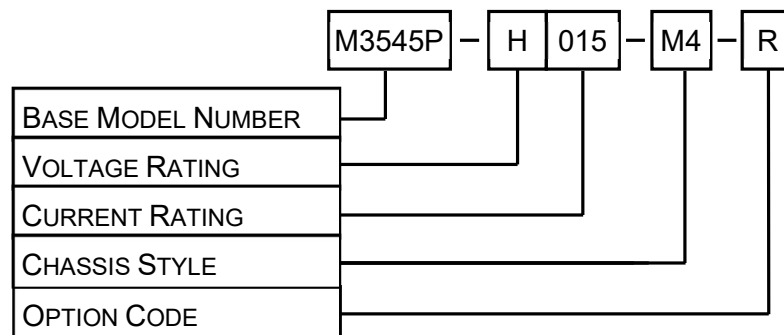

BASE MODEL NUMBER

The Base Model Number for these regenerative power supply is **M3545P**.

VOLTAGE RATING

A code letter represents the AC line voltage of the power supply module. The voltage rating must be selected for the system voltage that will be applied. See Table 2-1 for available voltage ratings.

Table 2-1: Voltage Ratings

RATING CODE	VOLTAGE
L	208 - 240VAC
H	380 - 480VAC

CURRENT RATING

A 3-digit number represents the maximum continuous DC current (Amps) the unit can regenerate. Each unit is capable of handling a 50% overload above this current rating for 60 seconds.

CHASSIS STYLE

The Chassis Style is determined by the current rating and is represented by an alphanumeric code as defined in Table 2-2.

Table 2-2: Chassis Styles

CHASSIS CODE	CURRENT	DESCRIPTION	SIZE (H x W x D)
C4	6A	Open Chassis	16" x 4.0" x 7.8"
A4 (obsolete)	6A	Open Chassis	14.8" x 4.0" x 7.8"
M4	15A	Open Chassis	17.0" x 4.7" x 10.8"

See Section 6.5 for chassis mounting and dimensional outlines.

OPTION CODE

The available option codes are listed in Table 2-3.

Table 2-3: Option Codes

OPTION CODE	DESCRIPTION
R*	Precharge (required for VFDs without precharge on DC terminals)

**Only available on 15A model.*

2.3. GENERAL SPECIFICATIONS CHART

Table 2-4: General Specifications

PARAMETER	SPECIFICATION
AC Line Voltage	<ul style="list-style-type: none"> • 208 - 480 VAC ±10% 50/60Hz
DC Input Current	3-Phase Operation
	<ul style="list-style-type: none"> • 6A, continuous • 9A for 60 second overload
	<ul style="list-style-type: none"> • 15A, continuous • 22.5A for 60 second overload
	1-Phase Operation
	<ul style="list-style-type: none"> • 2A, continuous • 3A, for 60 second overload
	<ul style="list-style-type: none"> • 5A, Continuous • 7.5A for 60 second overload
Maximum Load Capacitance	<ul style="list-style-type: none"> • 10,000 uF (-R option only)
Indicators	<ul style="list-style-type: none"> • 3 Status LEDs <ul style="list-style-type: none"> • Power, Regen, Not Ready
Inputs	<ul style="list-style-type: none"> • Fault Blink <ul style="list-style-type: none"> ○ 24VDC - 5mA
Outputs	<ul style="list-style-type: none"> • Ready <ul style="list-style-type: none"> ○ Normally Open, Solid State Relay
Operating Temp	<ul style="list-style-type: none"> • 0 to +40°C
Storage Temp	<ul style="list-style-type: none"> • -20° to +65°C
Humidity	<ul style="list-style-type: none"> • Below 90%, non-condensing
Atmosphere	<ul style="list-style-type: none"> • Free of corrosive gas or conductive dust

2.4. GENERAL PRECAUTIONS AND SAFETY WARNINGS



- **HIGH VOLTAGES MAY BE PRESENT!**
- **NEVER ATTEMPT TO OPERATE THIS PRODUCT WITH THE ACCESS DOORS OR COVERS OPENED!**
- **NEVER ATTEMPT TO SERVICE THIS PRODUCT WITHOUT FIRST DISCONNECTING POWER TO AND FROM THE UNIT!**
- **FAILURE TO HEED THESE WARNINGS MAY RESULT IN SERIOUS BODILY INJURY OR DEATH!**



- **THIS PRODUCT WILL GENERATE HIGH AMBIENT TEMPERATURES DURING OPERATION.**
- **THIS PRODUCT SHOULD BE INSTALLED ON A NON-FLAMMABLE SURFACE WITH CLEARANCES OF AT LEAST TWO INCHES IN ALL DIRECTIONS.**
- **ALWAYS ALLOW AMPLE TIME FOR THE UNIT TO COOL BEFORE ATTEMPTING SERVICE ON THIS PRODUCT.**
- **BEFORE ATTEMPTING INSTALLATION OR REMOVAL OF THIS PRODUCT, BE SURE TO REVIEW ALL DRIVE AND/OR RESISTIVE LOAD DOCUMENTATION FOR PERTINENT SAFETY PRECAUTIONS.**
- **INSTALLATION AND/OR REMOVAL OF THIS PRODUCT SHOULD ONLY BE ACCOMPLISHED BY A QUALIFIED ELECTRICIAN IN ACCORDANCE WITH NATIONAL ELECTRICAL CODE OR EQUIVALENT REGULATIONS.**

ANY QUESTIONS AS TO APPLICATION, INSTALLATION OR SERVICE SAFETY SHOULD BE DIRECTED TO THE EQUIPMENT SUPPLIER.

3. INSTALLATION INSTRUCTIONS



Installation and/or removal of this product should only be performed by a qualified electrician in accordance with National Electrical Code or local codes and regulations.

Proper installation of the M3545P regenerative power supply modules should be accomplished following the steps outlined below. Be sure to refer to the AC drive instruction manual as these steps are performed. Please direct all installation inquiries that may arise during the installation and start-up of this product to the equipment supplier or system integrator.

3.1. ENVIRONMENT

The module should be installed in an area protected from moisture and falling debris. Buildup of dust or debris may cause poor performance and possibly a failure. Operating in a wet environment can pose a shock hazard. The recommended temperature range for operating this module is 0 to +40°C.

3.2. UNPACKING

Upon receipt of this product, please verify that the product received matches the product that was ordered and that there is no obvious physical damage to the unit. If the wrong product was received or the product is damaged in any way, please contact the supplier from which the product was purchased.

3.3. MOUNTING

The installation site for the module should be chosen with several considerations in mind:

- When mounting the units in an enclosure, power dissipation should be taken into account. Refer to Section 6.2 Watt Loss for details.
- The unit requires a minimum clearance of two (2) inches in all directions around it when not mounted near a heat source. Heat sources may increase necessary clearances.
- Unit should not be exposed to falling debris or condensation.

Once the installation site has been selected as outlined above, the unit should be mounted in place.

The M3545P must be correctly oriented for proper heat flow through the unit. The M3545P must be mounted with the rear surface of the unit to the mounting surface. The unit may be mounted vertically or horizontally as shown in Figure 3-1A and 3-1D.

Do Not mount the unit in an upside-down position or on the underside of a mounting surface as shown in Figure 3-1B and 3-1E.

Do Not mount the unit in a horizontal position with its side parallel to the mounting surface or floor as shown in Figure 3-1C.

See Figure 6-1 for dimensional outline.

Figure 3-1: M3545P Mounting Orientation

Figure 3-1A

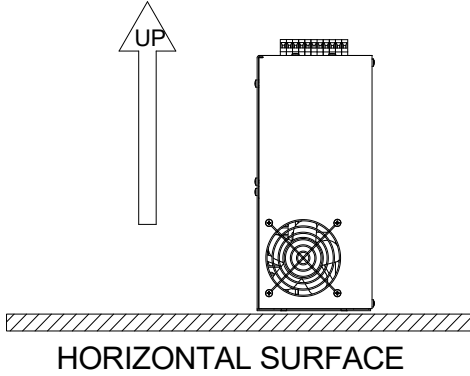

Figure 3-1D

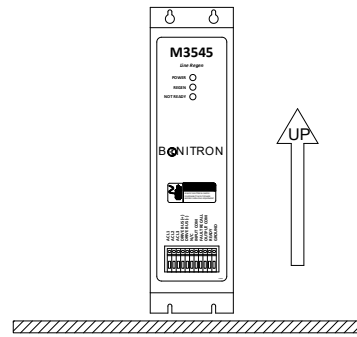

Figure 3-1B

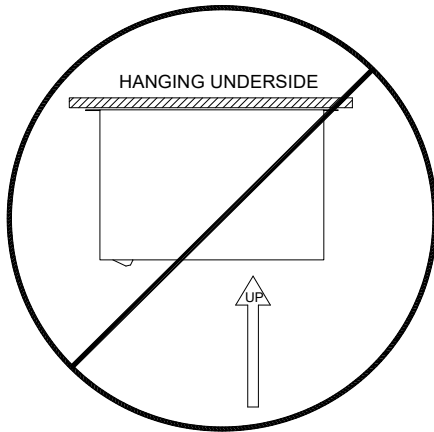

Figure 3-1E

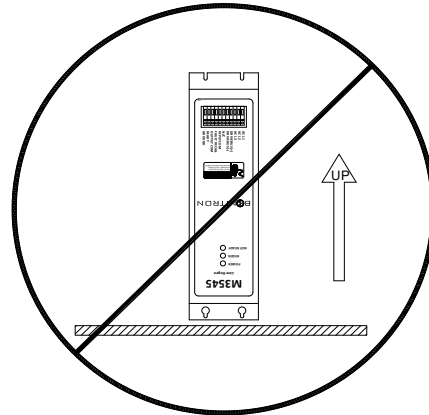
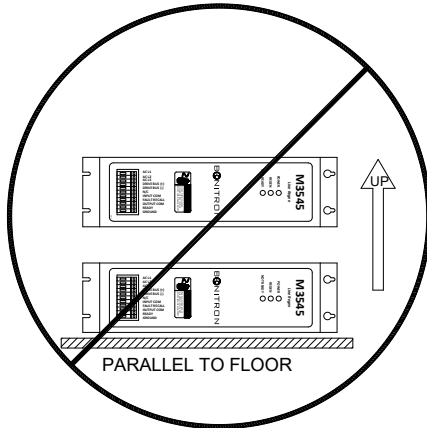

Figure 3-1C



3.4. WIRING AND CUSTOMER CONNECTIONS

All power and user I/O wiring connections are brought out to the terminal block in the front face of the unit; there should be no need to open the chassis during installation. Be sure to review all pertinent AC drive and system documentation as well as the information listed below before proceeding. Connection points and terminal numbers of the AC drive will be found in the documentation provided with those units.

See Tables 3-1 and 3-2 and Figures 3-2 through 3-5 for connection details.

3.4.1. POWER WIRING

Power connections are on the terminal block on TB-1 through TB-5. See Figure 3-2.

- Where possible, minimize the DC wire length between the M3645P and the drive. The wire length should not exceed 10 feet.
- Avoid routing and bundling the unit's AC/DC wire along with the drive output leads to the motor.



Only qualified electricians should perform and maintain the interconnection wiring of this product. All wiring should be in accordance with local codes.

3.4.1.1. AC LINE

- The AC Line connections should be to a source rated for at least 150% of the continuous current rating. This will ensure sufficient source impedance to return power to the grid.
- Do not install any external chokes or reactors between the M3545P and the power source; the M3545P has an internal 5% reactor.
- A properly rated isolation transformer may be installed between the M3545P and the power source, if desired.
- Do not connect to a generator unless minimum load at any time exceeds the peak expected regen power.
- The M3545P units are not phase sensitive.
- The AC Line connections should have short-circuit current protection. See Table 6-3.
- To use the M3545P on a single-phase AC grid, you MUST connect to AC L1 (TB-1) and AC L2 (TB-2).

3.4.1.2. DC BUS

- The DC bus connections may be made to the DC bus of an AC drive, or to a common DC bus.
 - If a reactor or choke are being used in the bus, make sure the actual connection is in parallel with filter capacitors of the drive/inverter.
- The DC bus connections should have short-circuit current protection. The recommended fuses are listed in Table 6-3.



Never attach the DC bus input of the M3545P to braking terminals on the AC drive, commonly marked "BR". These terminals are intended for use with an external resistor, and are not directly connected to the bus filter capacitors of the drive. Damage may occur if these terminals are used. Please refer to your AC drive manual or AC drive technical support department for assistance with this connection.

3.4.1.3. GROUNDING

Using the GND TB-11 on the terminal block, ground the chassis in accordance with local codes. Typically, the wire gauge will be the same as is used to ground the attached drive.

Table 3-1: Power Terminal Specifications

TERMINALS	FUNCTION	ELECTRICAL RATINGS	WIRE SIZE	TORQUE
L1, L2, L3	AC line	15A	12 AWG	7 lb-in
DC+, DC-	DC bus	15A	12 AWG	7 lb-in
	Ground		12 AWG	7 lb-in

Note: All power wire should copper wiring rated to 75°C or equivalent; and should be selected to match or exceed the voltage rating of the Regen unit. Ground wiring should be, at smallest, one gauge smaller than the selected power wiring.

Figure 3-1: 6 Amp M3545P Power & I/O Connection Location

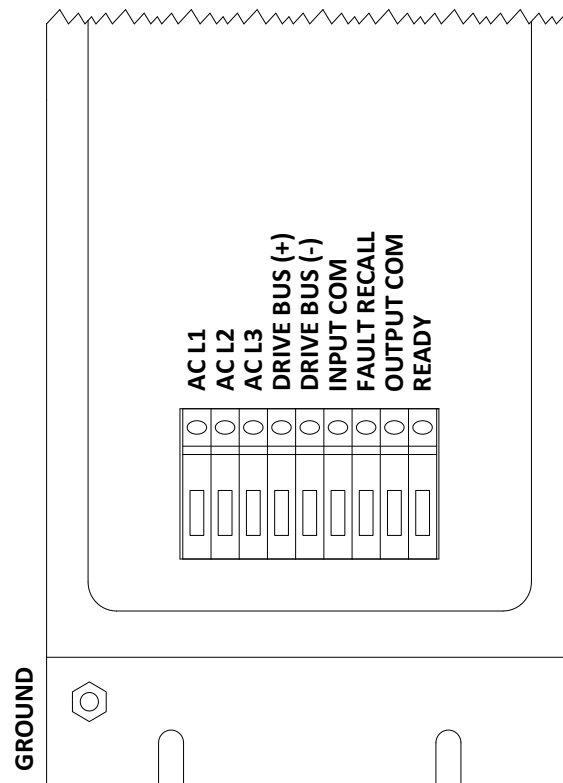
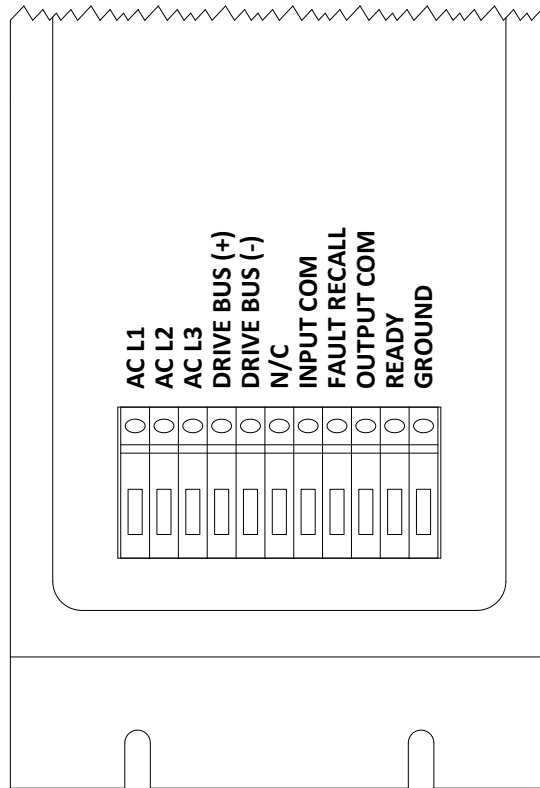

Figure 3-2: 15 Amp M3545P Power & I/O Connection Location



3.4.2. I/O WIRING

User I/O is connected on the terminal block to TB-6 through TB-10.

Table 3-2: M3545P 6 Amp I/O Wiring

TERMINALS	FUNCTION	ELECTRICAL RATINGS	WIRE SIZE MINIMUM	WIRE SIZE MAXIMUM	TORQUE
TB-6	Input COM	COM to TB-8	18	16	2.2 lb-in
TB-7	Fault Recall	24 VDC, 5mA	18	16	2.2 lb-in
TB-8	Output COM	COM to TB-10	18	16	2.2 lb-in
TB-9	Ready	150 VAC, 150 mA	18	16	2.2 lb-in

Table 3-3: M3545P 15 Amp I/O Wiring

TERMINALS	FUNCTION	ELECTRICAL RATINGS	WIRE SIZE MINIMUM	WIRE SIZE MAXIMUM	TORQUE
TB-6	N/C				
TB-7	Input COM	COM to TB-8	18	16	2.2 lb-in
TB-8	Fault Recall	24VDC, 5mA	18	16	2.2 lb-in
TB-9	Output COM	COM to TB-10	18	16	2.2 lb-in
TB-10	Ready	150VAC, 150mA	18	16	2.2 lb-in

Figure 3-3: 6 Amp M3545P I/O Diagram

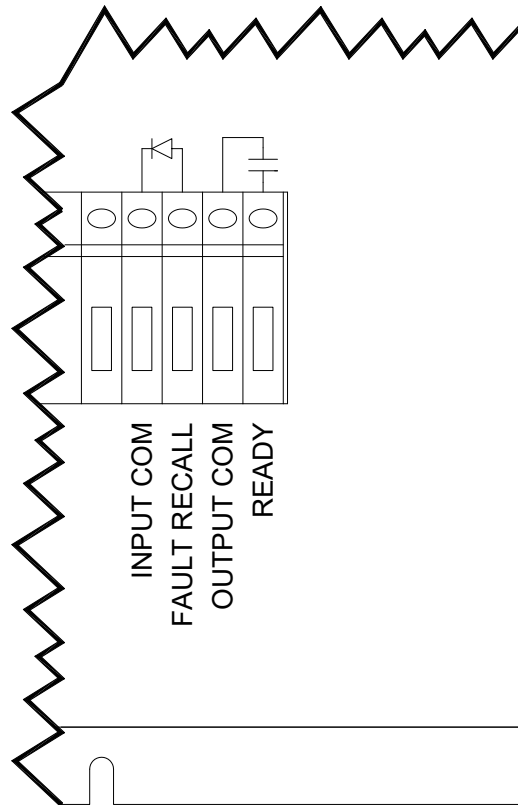
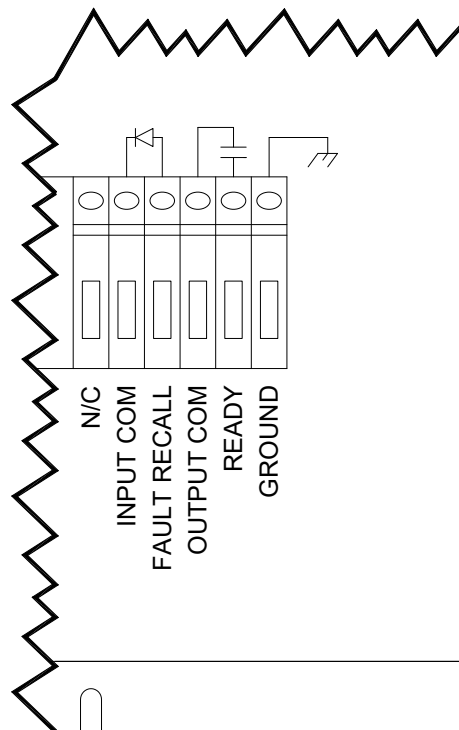

Figure 3-4: 15 Amp M3545P I/O Diagram



3.5. TYPICAL CONFIGURATIONS

The diagrams shown in Figure 3-6 and Figure 3-7 illustrate typical connections of the M3545P units with generic VFDs. There are many other configurations that may be applied provided a basic connection criterion is maintained such as:

- The AC Line connections should maintain a low impedance path back to the grid.
- No reactors should be connected upstream of the M3545P unit without consulting Bonitron for instructions.
- The DC link should never be connected to a switching source such as the braking resistor terminals on some drives.
- The DC link should not be connected to an active front end drive without instructions from Bonitron.
- Any capacitive load requires precharge. Ensure that either the load has internal precharge, or that the M3545P unit has a –R option. This option is only available on 15 Amp units. Units without the –R option do not support precharge of any amount of capacitance. Applying power with no precharge in the system will result in fuse failure, and possible damage to the unit and load.

Figure 3-5: M3545P Power Wiring

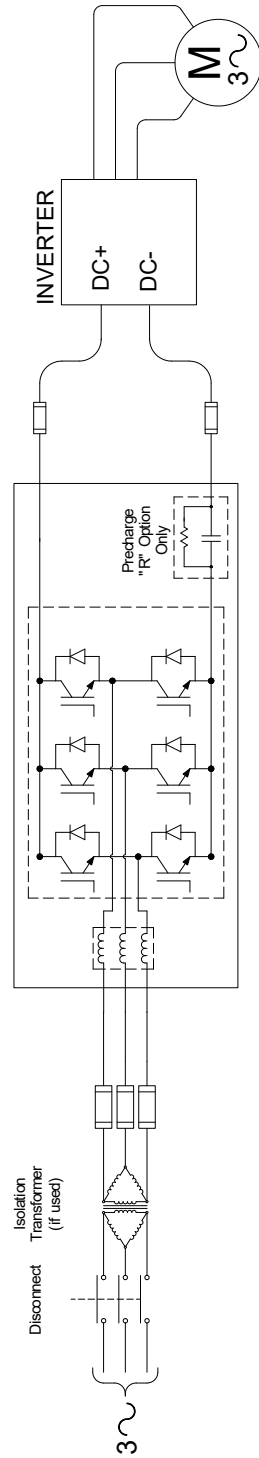
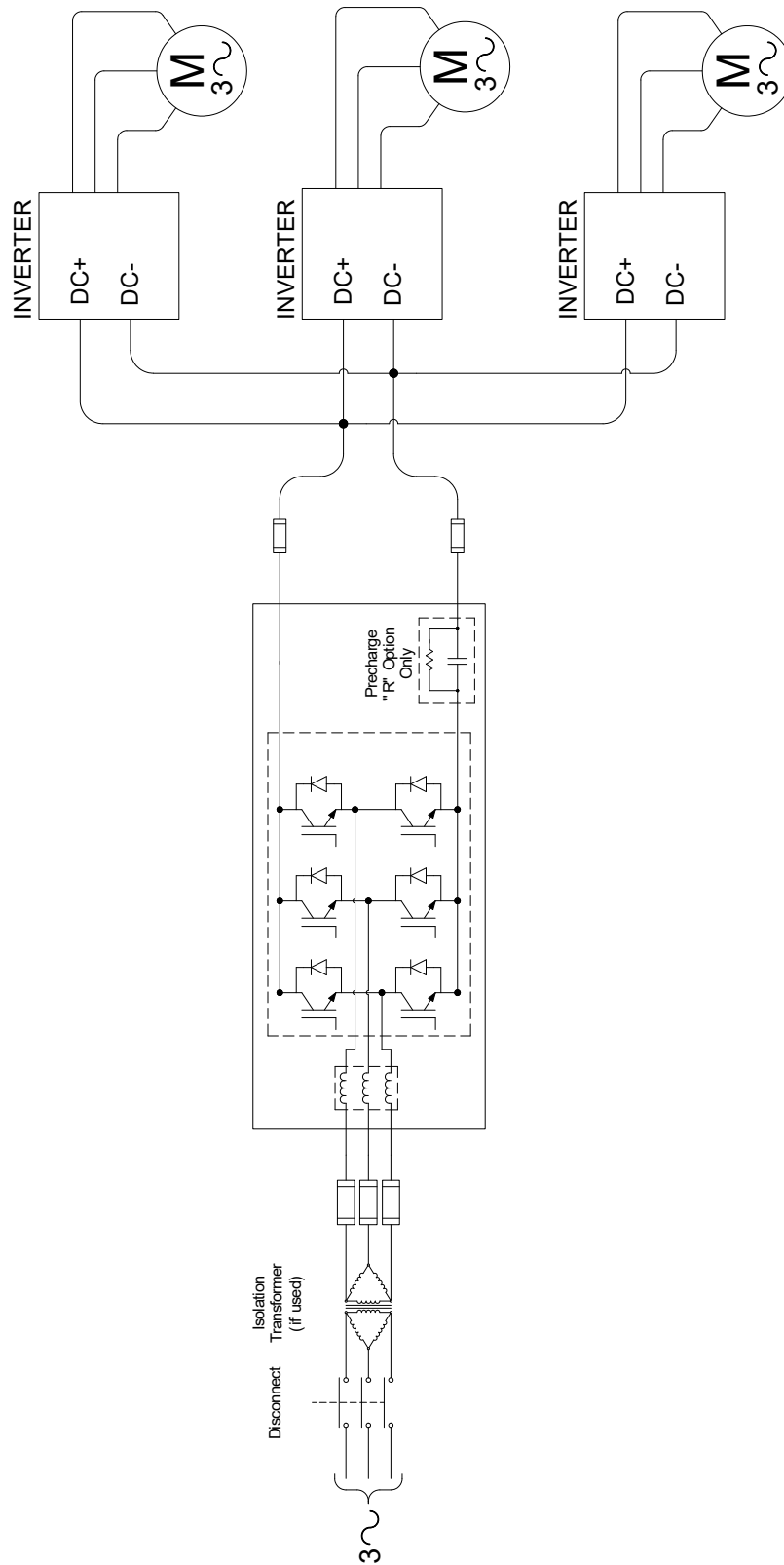

Figure 3-6: M3545P Multiple Drives Field Wiring Diagram



OPERATION

3.6. FUNCTIONAL DESCRIPTION

The M3545P regenerative power supply can power one or more drives through the DC bus. During motoring, the unit acts as a simple diode bridge rectifier with an internal 5% reactor. 15 Amp M3545P units with an –R option code will precharge a capacitive load, up to their maximum specified load capacitance. Units without this code can only be used with drives that can precharge from their DC terminals.

If the DC voltage begins to rise, due to braking or an over-hauling motor, the M3545P acts as a 6-pulse inverter to efficiently sink this excess energy back to the power grid. The M3545P is regen current-limited; it will fold back if the regen currents rise to unsafe levels. Fault conditions are monitored and stored in persistent memory and the last fault state can be shown on the fault indicator.

3.7. FEATURES

3.7.1. INDICATOR LEDs

3.7.1.1. POWER – GREEN LED

Indicates that the AC voltage is present at the unit and the unit is powered on.

3.7.1.2. REGEN ACTIVE – YELLOW LED

This means the unit is actively regenerating. Current is flowing from the drive DC bus out to the AC line.

3.7.1.3. NOT READY – RED LED

This indicates when there is a problem with the unit.

FLASHING RED means that a fault has occurred. The number of flashes indicates the specific fault(s) (see Table 4-1).

3.8. FAULTS

The Ready Output contact will be open while the unit is in a faulted state.

3.8.1. OPERATIONAL FAULTS

The M3545P monitors several internal parameters during operation. If any of them deviate beyond their safe boundaries, the M3545P will halt operation and blink a fault code to indicate the nature of the problem. These faults are indicated by a FLASHING RED LED.

All of these faults, with the exception of IGBT Desat, will auto clear so that the unit can resume operation as soon as it is safe to do so.

Table 3-4: Blink Codes

FLASHES	FAULT	AUTO CLEAR
1	Phase Loss	Yes
2	Over Temp	Yes
3	Over Voltage	Yes
4	IGBT Desat	No

3.8.1.1. PHASE LOSS

Phase Loss fault indicates that the unit has lost feedback from L3 on the AC connections. This fault clears itself 10 seconds after the condition is cleared.

3.8.1.2. OVER TEMP

Over Temp fault indicates that some internal components have exceeded their operating temperatures. This fault will clear after the unit cools down.

3.8.1.3. OVER VOLTAGE

Over Voltage fault occurs when the internal DC bus voltage rises to unsafe levels during operation. This fault clears itself 10 seconds after the condition is cleared.

3.8.1.4. IGBT DESAT

This fault indicates the internal transistor drive circuitry has detected an error. This fault must be manually cleared as it usually indicates a failure elsewhere in the system.

3.8.2. SYSTEM FAULTS

Additionally, there are several system faults that indicate the microprocessor has encountered a critical error. These faults are indicated by a SOLID RED LED and a FLASHING YELLOW LED.

Table 3-5: System Faults

FLASHES	PROCESSOR ERROR	AUTO CLEAR
1	Clock	No
2	Address	No
3	Stack	No
4	Math	No

3.9. USER I/O CONNECTIONS

All of the user inputs to the regen are 24VDC, active-high logic, and must be referenced to the INPUT COM terminal. The outputs are dry contacts that close to the OUTPUT COM terminal.

Table 3-6: M3545 6A User I/O Terminals

USER I/O	TERMINALS	ELECTRICAL RATING
Input COM	TB-6	All user inputs are referenced to this terminal.
Fault Recall*	TB-7	Activating this input while the unit is idle will cause it to blink out the most recent fault state.
Output COM	TB-8	All user outputs are referenced to this terminal.
Ready Output	TB-9	This output closes to TB-8 when the regen unit is ready to operate. This contact will open if the unit is faulted.

*If equipped with the optional enable firmware, this input becomes an Enable input. To recall a fault, toggle the enable three times.

Table 3-7: M3545 15A User I/O Terminals

USER I/O	TERMINALS	ELECTRICAL RATING
Input COM	TB-7	All user inputs are referenced to this terminal.
Fault Recall*	TB-8	Activating this input while the unit is idle will cause it to blink out the most recent fault state.
Output COM	TB-9	All user outputs are referenced to this terminal.
Ready Output	TB-10	This output closes to TB-9 when the regen unit is ready to operate. This contact will open if the unit is faulted.

*If equipped with the optional enable firmware, this input becomes an Enable input. To recall a fault, toggle the enable three times.

3.10. STARTUP

This section covers basic checks and procedures that should be used when performing a startup with a M3545P regenerative power supply.



Multiple repeated precharge cycles can damage the M3545's precharge resistor. Ensure that no more than five precharge cycles take place within a five minute span.

3.10.1. PRE-POWER CHECKS

- Verify that the voltage of the AC power system is the same as the unit.
- Ensure that all connections are tight and that all wiring is of the proper size and rating for operation.
- Verify continuity of all fuses prior to applying power.
- Check for exposed conductors that may lead to inadvertent contact.
- Check for any debris, shavings, trimmings, etc. that may cause shorts or obstruct ventilation on unit.

3.10.2. STARTUP PROCEDURE AND CHECKS

After completing pre-checks and recommended checks for connected equipment you may apply power to the system.

- The green Power LED should light up and stay on. This indicates that the regenerative power supply is powered on.
- Both red and yellow indicator LEDs should illuminate on the front panel and the fan should turn on for 3 sec.
- The red and yellow LEDs will then toggle once or three times to indicate how many AC phases the unit has detected.
- Finally, the Not Ready and Regen Active LEDs should turn off and the Ready Output contact will close.

The drive system can now be run normally.

3.10.3. COOLING FAN

The cooling fan runs when the unit is active (braking event), and stays on for 10 minutes after the active event ends. If the unit gets too hot, the fan will stay running until the unit's internal temperature falls below the threshold.

This page intentionally left blank

4. MAINTENANCE AND TROUBLESHOOTING

Repairs or modifications to this equipment are to be performed by Bonitron approved personnel only. Any repair or modification to this equipment by personnel not approved by Bonitron will void any warranty remaining on this unit.

4.1. PERIODIC TESTING

While there are no requirements for periodic testing of these units, it may be beneficial to repeat the start-up checks when performing routine maintenance on other drive components in the system.

4.2. MAINTENANCE ITEMS

Check the fan periodically for debris, and blow out with an air hose if it has become obstructed or not running at full capacity. **Power should not be applied when blowing dust and debris out of unit.**

4.3. TROUBLESHOOTING



There are no user serviceable parts within the M3545P. If you are still experiencing problems after you have reviewed this whole section you may contact Bonitron for additional assistance at (615) 244-2825.

4.3.1. POWER LED IS NOT ON

- Check the AC voltage at the terminals of the M3545P. Voltage should be within the range specified for your unit. (See Section 2.)
- Check any overcurrent devices or disconnects in the AC line upstream of the M3545P.
- It is possible that the unit has been damaged and will need repairs.

4.3.2. READY OUTPUT WILL NOT CLOSE

The Ready output indicates that the module is ready to operate. It should only be open when the unit is faulted.

- Make sure the Power LED is on.
- If the Fault LED is FLASHING, refer to Section 4.3 to determine what fault conditions are present.

4.3.3. OVER VOLTAGE FAULT ON DRIVE OR REGEN

If the attached drive regularly trips during braking, the unit is most likely not operating. There are some simple things to check to determine the cause:

- Check the DC bus voltage at fuses.
- Check the DC bus polarity at fuses.
- Verify the DC link fuses have not cleared.
- Make sure the M3545P is powered on. The Ready Output should close when the unit is ready to operate.
- Any faults that occur will prevent the unit from running. Check the Fault LED and clear any existing fault conditions

4.3.4. OVERTEMPERATURE FAULT

- Ensure there is adequate clearance and airflow around the installation location.
- Check the ambient temperature. If it is above 40°C, the unit may not be able to properly cool at full load.
- Make sure the fan is actually operating.
 - The fan should be running when the unit is Active (yellow LED lit).
 - Check for any obstructions and cycle power to the unit. The fan should run for three (3) seconds during start-up.

4.3.5. IGBT DESAT FAULT

If the fault cannot be cleared, or occurs frequently, the unit may be damaged. Contact Bonitron for assistance.

4.3.6. PHASE LOSS FAULT

If this fault does not reset, it typically means the AC line fuses or disconnects have cleared. Power down the system and check all fuses and overcurrent disconnects. Make sure that voltage is present at the terminals appropriate for the ratings of your unit.

4.3.7. FUSES FAIL ON POWER ON

Ensure that appropriate precharge is present in either the load VFD or in the 15 Amp M3545P (-R option). If precharge is present and fuses continue to fail, contact Bonitron for assistance.

4.4. TECHNICAL HELP – BEFORE YOU CONTACT US

If technical help is required, please have the following information available when contacting Bonitron (615-244-2825 email: info@bonitron.com):

- Model number of unit
- Serial number of unit
- Name of original equipment supplier if available
- Record the line to line voltage on all 3 phases
- Record the DC bus voltage immediately after the AC voltage
- Brief description of the application
- Drive and motor HP or kW
- KVA rating of power source
- Source configuration Wye/Delta and grounding

5. ENGINEERING DATA

5.1. RATINGS CHARTS

Table 5-1: Ratings and Specifications – 208 - 240VAC

MODEL NUMBERS	PHASE	CHASSIS STYLE	DC REGEN CURRENT		POWER		MAX CONT. WATT LOSS
			CONT.	PEAK	CONT.	PEAK	
M3545P-L006	1	C4	2 A	3 A	0.9 HP	1.4 HP	34 W
	3		6 A	9 A	2.8 HP	4.2 HP	59 W
M3545P-L006	1	A4 (obsolete)	2 A	3 A	0.9 HP	1.4 HP	34 W
	3		6 A	9 A	2.8 HP	4.2 HP	59 W
M3545P-L015	1	M4	5 A	7.5 A	2.25 HP	3.5 HP	67 W
	3		15 A	22.5 A	7 HP	10.5 HP	117 W

Table 5-2: Ratings and Specifications – 380 - 480VAC

MODEL NUMBERS	PHASE	CHASSIS STYLE	DC REGEN CURRENT		380 POWER		480 POWER		MAX CONT. WATT LOSS
			CONT.	PEAK	CONT.	PEAK	CONT.	PEAK	
M3545P-H006	1	C4	2 A	3 A	1.5 HP	2.5 HP	1.8 HP	2.8 HP	34 W
	3		6 A	9 A	5 HP	7.5 HP	5.6 HP	8.4 HP	59 W
M3545P-H006	1	A4 (obsolete)	2 A	3 A	1.5 HP	2.5 HP	1.8 HP	2.8 HP	34 W
	3		6 A	9 A	5 HP	7.5 HP	5.6 HP	8.4 HP	59 W
M3545P-H015	1	M4	5 A	7.5 A	4 HP	6 HP	4.5 HP	7 HP	67 W
	3		15 A	22.5 A	12.5 HP	18.7 HP	14 HP	21 HP	117 W

A NOTE ON HP RATINGS

Modules are able to provide full **braking HP** for at least **60 seconds**. Modules can provide less than full braking HP for longer times.

Each unit's maximum current must be derated by 2% per degree Celsius ambient above 40°C.

5.2. DERATING PARALLEL M3545P

Operating regenerative power supplies are useful when large regenerative energies are present and need to be dissipated in high power applications.

The combined units must be derated by 10% each. The derating for parallel systems is shown in Table 6-3.

Two units are the maximum number that can be safely operated in parallel. Units with different current ratings should not be in parallel together on the same DC bus.

Table 5-3: Derating M3545P in Parallel

INDIVIDUAL UNIT CURRENT RATING	NUMBER IN PARALLEL	DC REGEN CURRENT	
		CONT.	PEAK.
15A	2	27A	36A

5.3. WATT LOSS

Tables 6-1 and 6-2 list the maximum watt loss generated by each of the M3545P units. When installing the units in an additional enclosure, consideration should be given to internal temperature rise. The watt loss rating in these tables is based upon the maximum continuous regen capability of each unit. The M3545P is >97% efficient when fully loaded.

5.4. CERTIFICATIONS

5.4.1. UL 61800-5-1

All M3545P models are UL Listed under this standard. UL file number E204386.

The M3545P regenerative power supply has a Short Circuit Current Rating (SCCR) of 65kA when protected by proper fusing. See Table 6-4 for required ratings and recommendations.

5.4.2. RoHS

All M3545P models are in compliance with Directive 2011/65/EU of the European Parliament and of the Council of 8 June 2011 on the restrictions of the use of certain hazardous substances in electrical and electronics equipment (RoHS Directives).

5.5. FUSE SELECTION

Blown fuses typically indicate a semiconductor device failure or a severe transient. In any case, blown fuses should not be replaced without first consulting Bonitron as catastrophic damage can occur.

Use Table 6-3 when initially constructing the system.

Table 5-4: Fuse Current Rating Requirements

	MODULE RATING	CURRENT RATING	VOLTAGE RATING	RECOMMENDED FUSE
AC LINE	15 A	20 A	600 VAC	A60Q20-2
DC LINK	15 A	20 A	700 VDC	A7QS20-14F
AC LINE	6 A	10 A	600 VAC	A60Q10-2
DC LINK	6 A	10 A	700 VDC	A70QS10-14F

5.6. DIMENSIONS AND MECHANICAL DRAWINGS

Figure 6 1: M3545P – 6 Amps C4 Chassis Dimensional Outline

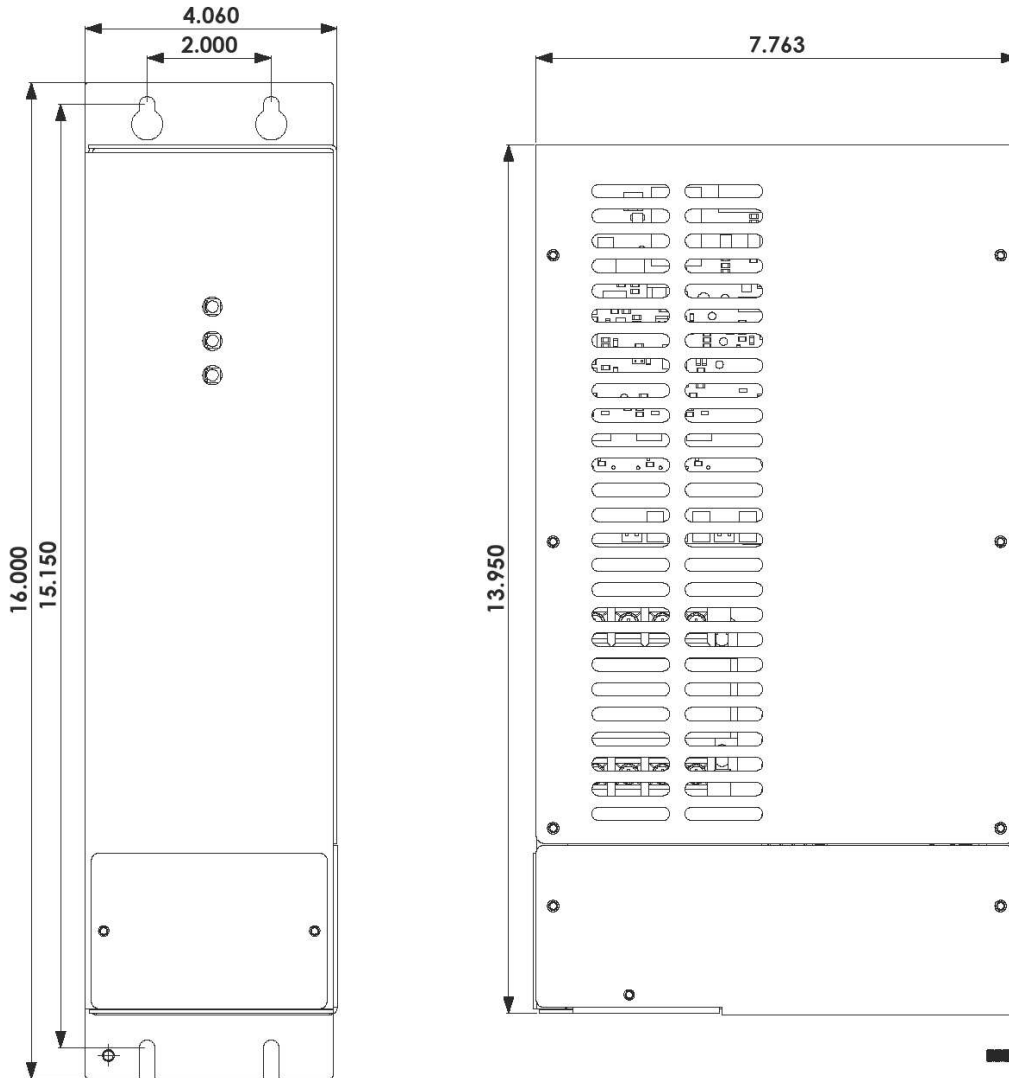

Figure 6 2: M3545P – 6 Amps A4 (Obsolete) Chassis Dimensional Outline

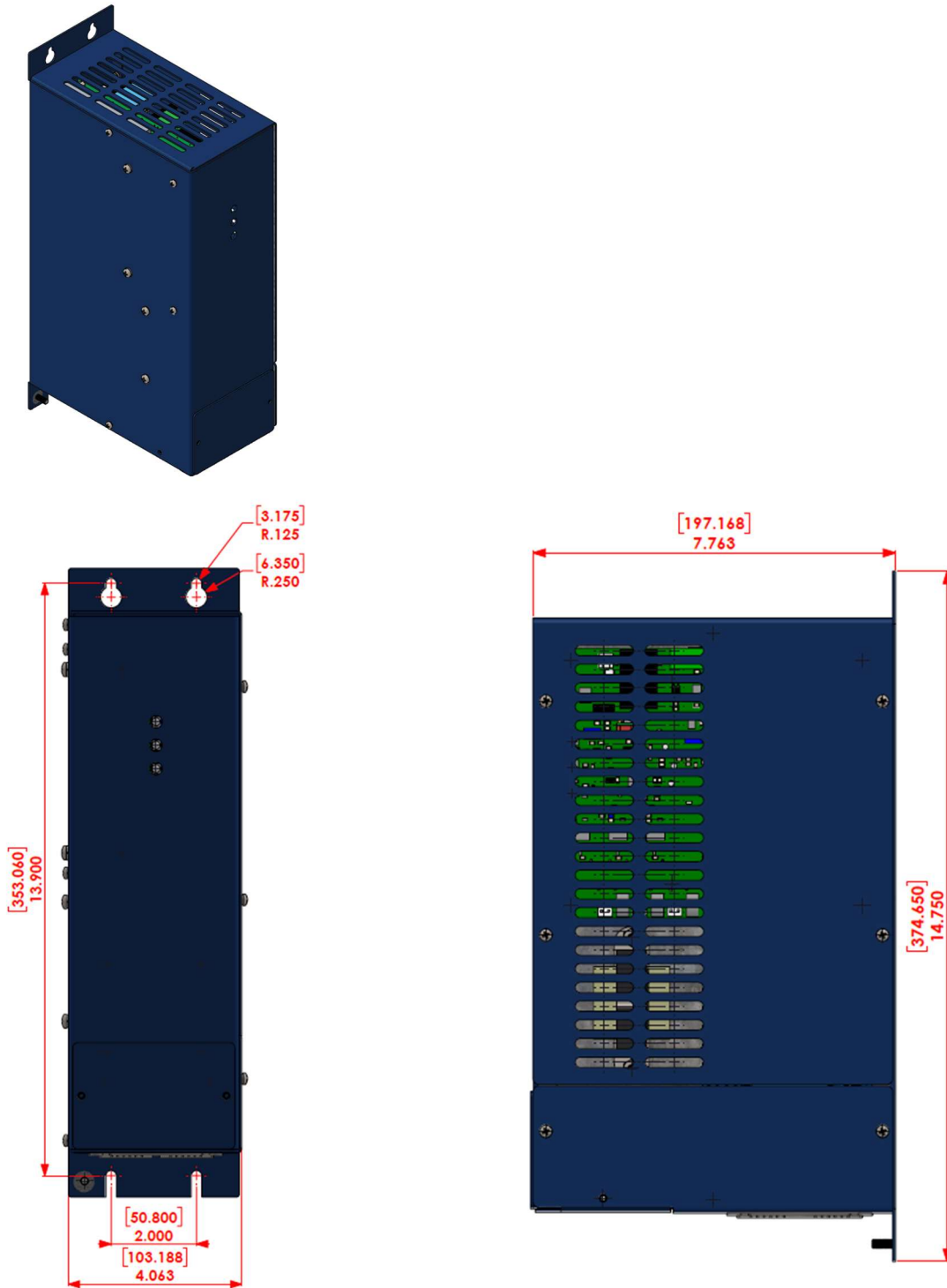
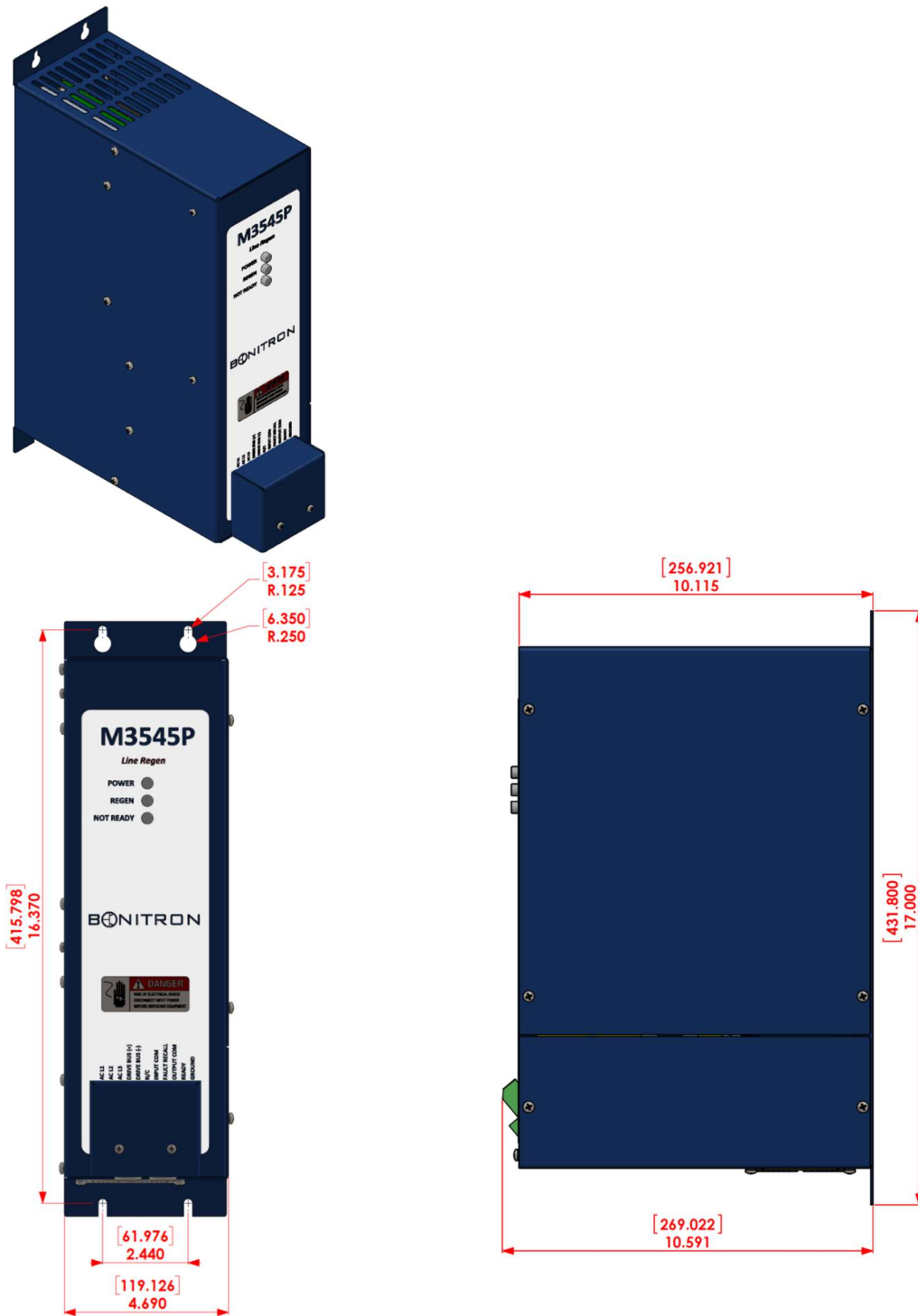

Figure 5-1: M3545P M4 Chassis Dimensional Outline



6. APPENDIX

6.1. APPLICATION NOTES

6.1.1. SIZING THE M3545P

The M3545P unit is sized for the amount of DC bus current, I_{DC} , which it must carry. To obtain the amount of DC bus current needed during deceleration; the load and motor inertias, desired change in RPM, and required stopping time must be known. With these application variables, the following calculations can be made to size the M3545P. Use the equation below to establish the torque required to decelerate or stop a rotating object. The equations below are valid for using the M3545P for three phase power.

CALCULATE MOTOR TORQUE

Calculating the motor torque

$$T = \frac{WK^2 \Delta N}{308 t_{on}}$$

Where

T is torque measured in lb·ft.

$$1.0 \text{ lb}\cdot\text{ft} = 1.355818 \text{ Nm}$$

WK^2 is the total inertial load to be decelerated (lb·ft²).

$$1.0 \text{ lb}\cdot\text{ft}^2 = 0.04214011 \text{ kg}\cdot\text{m}^2$$

ΔN is the change in rotational speed (rpm).

308 is a constant

t_{on} is time required to decelerate the load (s).

CALCULATE MOTOR POWER

Calculating the power (HP) regenerated:

$$P = \frac{TN_{max}}{5252}$$

Where

N_{max} is the maximum rotational speed (rpm).

The constant 5252 has units of lb·ft/min/radian.

CALCULATE DC BUS CURRENT

Calculating the regenerated DC bus current, I_{DC} .

$$I_{DC} = \frac{P(746 \frac{W}{HP})}{\sqrt{2}V_{AC}}$$

The DC bus current, I_{DC} , is approximated for the following AC line voltages:

$$\text{For } 230 \text{ V}_{AC} \text{ systems: } I_{DC} = (2.4)P$$

$$\text{For } 380 \text{ V}_{AC} \text{ systems: } I_{DC} = (1.4)P$$

$$\text{For } 460 \text{ V}_{AC} \text{ systems: } I_{DC} = (1.2)P$$

$$\text{For } 575 \text{ V}_{AC} \text{ systems: } I_{DC} = (1.0)P$$

Once I_{DC} is known, you will be able to appropriately size the line regen based upon its current rating.

6.1.2. CALCULATING ENERGY SAVINGS

The M3545P directs energy from the mechanical load to the power distribution line, where the energy is available to other connected loads. These units provide system energy savings over dynamic braking kits, because the net energy required from the distribution system is reduced by the regenerated energy. Additional savings also come from the lack of a need to provide air conditioning with a dynamic braking kit and from reduced time spent stopping loads.

To calculate the savings, the regeneration duty cycle, the length of operation, the regenerated HP, and the cost of energy must be known. With these application variables, the following calculation may be made to determine the cost savings:

CALCULATE SAVINGS PER YEAR

Calculating total savings per year in dollars:

$$S = \frac{CP(0.746 \frac{kW}{HP})DHt_{on}}{t_{cycle}}$$

Where

S is Savings per year.

C is the cost in dollars per kW.

P is the regenerated power.

D is the number of days the system is operated.

H is the number of hours per day the system is operated.

t_{on} is the number of seconds per cycle T power is regenerated.

t_{cycle} is the total time to complete a cycle.

SAVING EXAMPLE

Assume the following values for this example:

C = \$0.11 per kW

P = 20HP peak, 15HP average during deceleration

D = 365 days

H = 10 hours per day

t_{on} = 5 seconds regen is on

t_{cycle} = 15 seconds

Savings:

$$S = \frac{(\$0.11/kW)(15HP)(0.746 \frac{kW}{HP})(365days)(10hours)(5s)}{(15s)}$$

$$S = \$1497.60$$

NOTES

